

PRELIMINARY
 Notice ; This is not a final specification.
 some parametric limits are subject to change.

MITSUBISHI SOUND PROCESSORS

M62464FP

Dolby Pro Logic Surround Decoder
 with Discrete 5.1ch Analog Input

Dolby Pro Logic Surround Decoder with Discrete 5.1ch Analog Input

Description

The M62464FP is a Single Chip Dolby Pro Logic Surround Decoder with Discrete 5.1ch Analog Input. This LSI has all of required functions for Dolby Pro Logic Surround and also 5.1ch analog input for Dolby Digital.

Dolby and the double-D symbol are trademarks of Dolby Laboratories Licensing Corporation. San Francisco, CA94103-4813, USA.

This device available only to licensees of Dolby Lab.

Licensing and application information may be obtained from Dolby Lab.

Outline

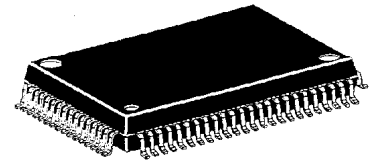

Outline 80P6N
 0.8mm pitch QFP
 (20.0mmx14.0mmx2.8mm)

Features

- Includes all functions necessary for Dolby Pro Logic Surround
- Includes 5.1ch(L,R,C,SL,SR,SW) analog input for Dolby Digital
- 4ch(C,SL,SR,SW) Master Volume
- Digital Space Surround such as Disco, Hall and Live
- Pseudo Stereo Surround for Digital Space Surround
- Digital Echo for Karaoke Function Delay time 123,184msec
- 3-lines MCU control
- Current control oscillation circuit for system clock

System Configuration

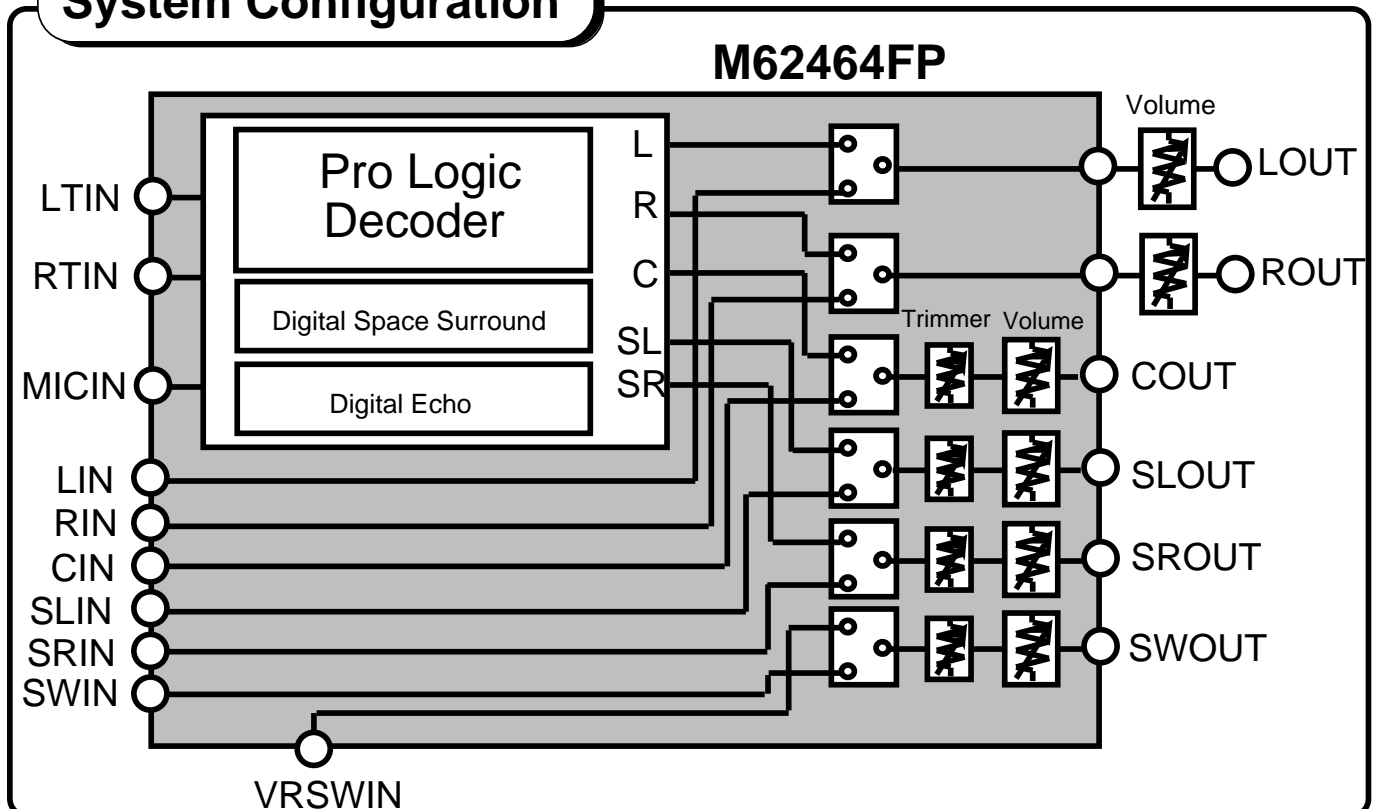

PRELIMINARY
 Notice ; This is not a final specification.
 some parametric limits are subject to change.

MITSUBISHI SOUND PROCESSORS
M62464FP
 Dolby Pro Logic Surround Decoder
 with Discrete 5.1ch Analog Input

Pin Configuration

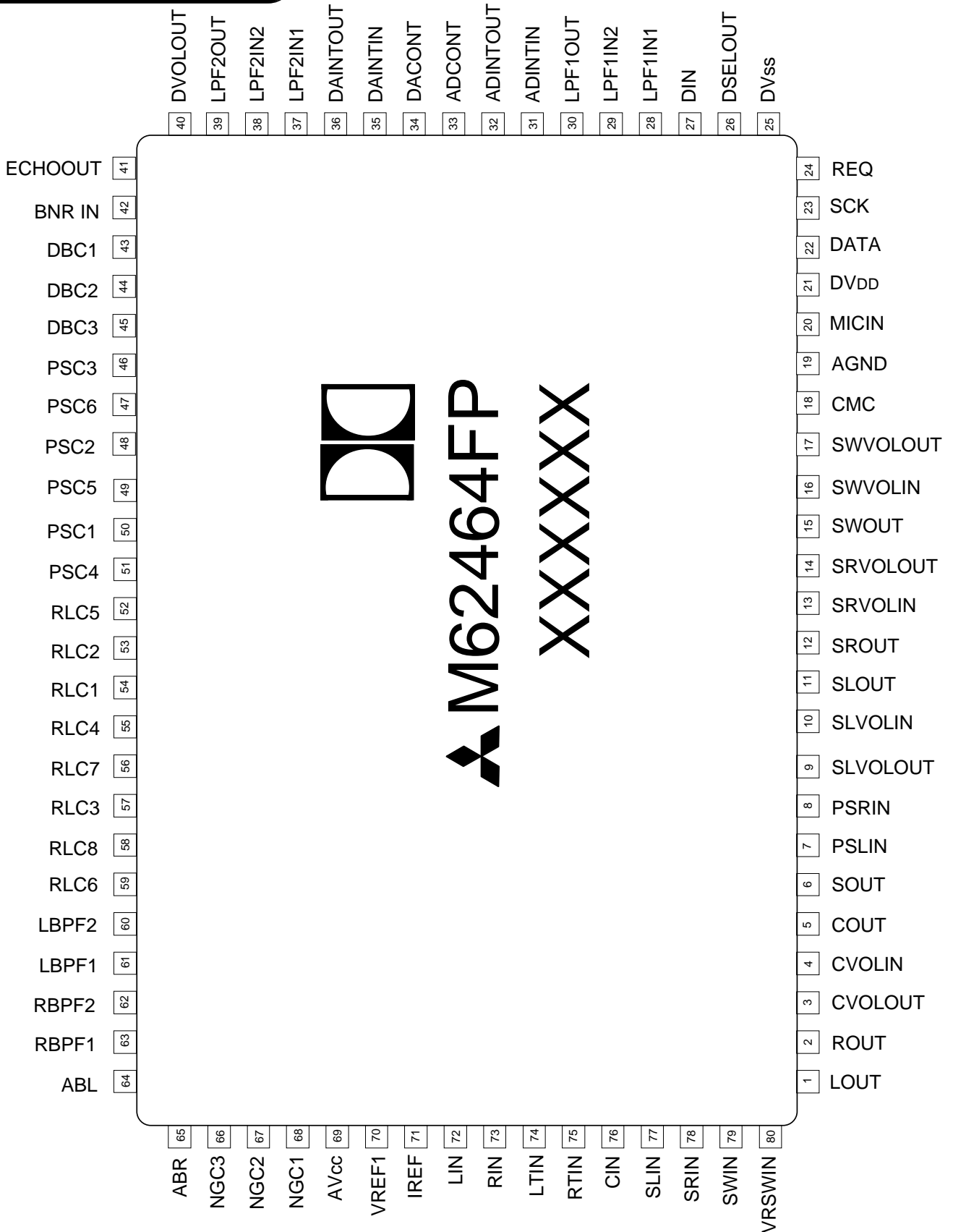

PRELIMINARY
 Notice ; This is not a final specification.
 some parametric limits are subject to change.

MITSUBISHI SOUND PROCESSORS

M62464FP

Dolby Pro Logic Surround Decoder
 with Discrete 5.1ch Analog Input

Block Diagram

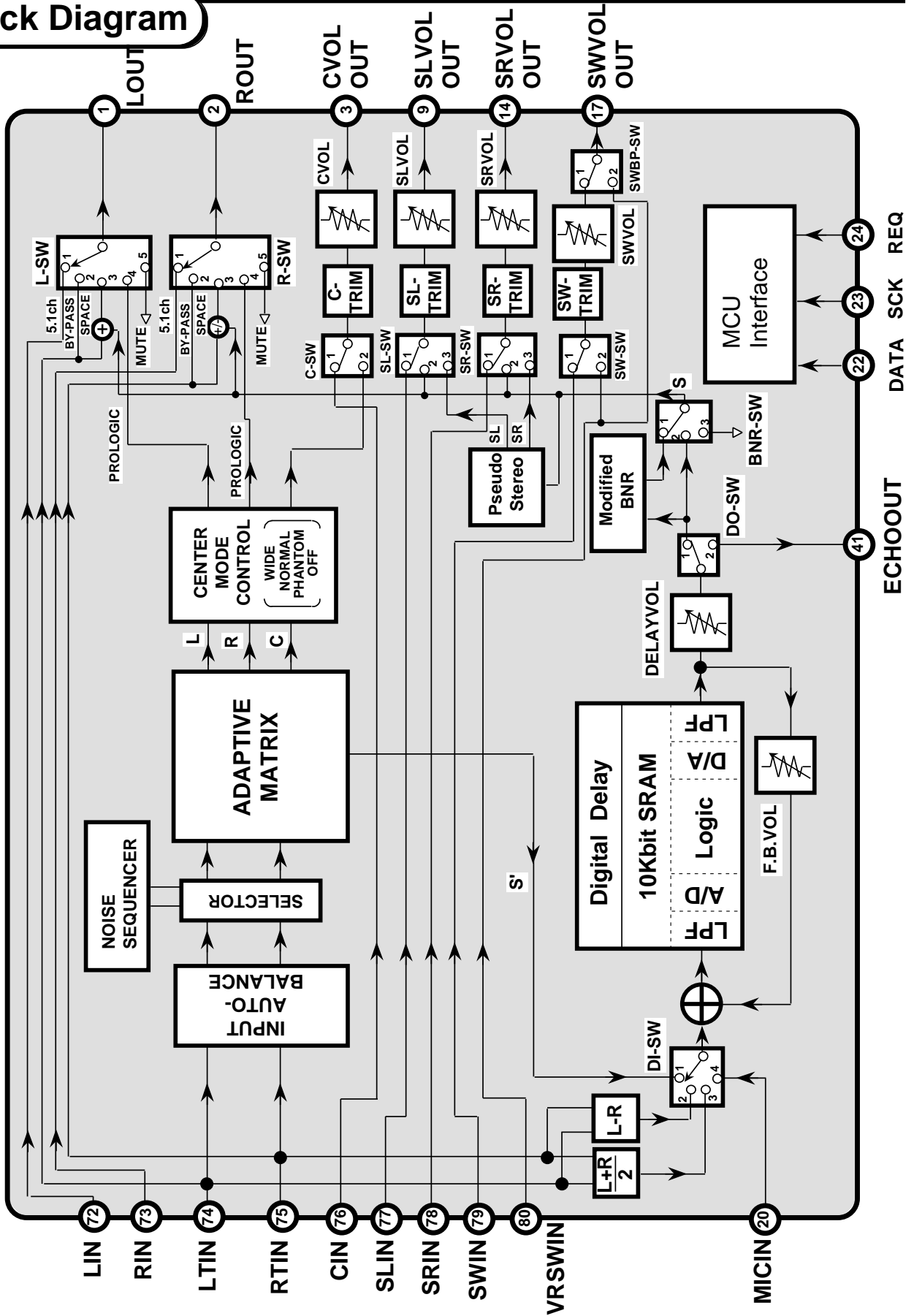

PRELIMINARY
 Notice ; This is not a final specification.
 some parametric limits are subject to change.

MITSUBISHI SOUND PROCESSORS
M62464FP
 Dolby Pro Logic Surround Decoder
 with Discrete 5.1ch Analog Input

FUNCTIONAL DESCRIPTION

FUNCTION		DESCRIPTION
1	Fundamental function for Dolby Pro Logic Surround Decoder	-Adaptive Matrix -Input Auto-Balance -Noise Sequencer -Center Mode Control ON/OFF WIDE/NORMAL/PHANTOM -Modified Dolby B type Noise Reduction -4ch(L,R,C,S), 3ch(L,R,C) Mode Switch
2	5.1ch Analog Input for Dolby Digital	L,R,C,SL,SR,SW ch Analog Input Support
3	C,SL,SR,SW ch Master Volume	0 to -79dB/1dB step, and -∞
4	C,SL,SR,SW ch Trimmer	0 to -31dB/1dB step
5	RAM for Digital Delay	10K-bit RAM
6	Circuit for Space Surround and Echo	Digital delay circuit can be used for Space Surround such as a Disco, Hall or Live, and Karaoke echo.
7	Pseudo Stereo Surround	Pseudo Stereo Surround is available in Space Surround.
8	Digital Delay Time	Short Delay 15.4, 20.5, 25.6, 29.2, 51.2 msec Long Delay 123, 184 msec
9	Feedback Volume	Delay Signal Feedback Volume -3 to -21 dB/3dB step, and -∞
10	Delay Effect Volume	Delay Signal Effect Volume 0 to -18 dB/3dB step, and -∞
11	Bypass Switch	Bypass the decode circuit
12	Output Mute	Mute the Lch and Rch output
13	MCU Interface	Controlled by 3-lines serial data from MCU Including the Chip Address (2 bit)
14	Current control oscillation circuit	Including the oscillation circuit without external parts.

PRELIMINARY
 Notice ; This is not a final specification.
 some parametric limits are subject to change.

ABSOLUTE MAXIMUM RATINGS

(Ta=25°C Unless otherwise noted)

Symbol	Parameter	Conditions	Ratings	Unit
Vcc	Supply Voltage		10.5	V
VDD			6.5	V
Pd	Power Dissipation		1.4	W
Topr	Operating Temperature		-20 to +75	°C
Tstg	Storage Temperature		-40 to +125	°C

RECOMMENDED OPERATING CONDITION

Symbol	Parameter	Condition	Limits			Units
			Min	Typ	Max	
Vcc	Supply Voltage		8	9	10	V
VDD			4.5	5	5.5	V
VIL	Input Voltage(L)	22,23,24pin	0	—	0.7	V
VIH	Input Voltage(H)	22,23,24pin	2.7	—	VDD	V

PRELIMINARY
 Notice ; This is not a final specification.
 some parametric limits are subject to change.

MITSUBISHI SOUND PROCESSORS
M62464FP
 Dolby Pro Logic Surround Decoder
 with Discrete 5.1ch Analog Input

ELECTRICAL CHARACTERISTICS

(Ta=25°C, Vcc=9V, VDD=5V, 0dBd=300mVrms, at COUT, f=1kHz unless otherwise noted)

Symbol	Parameter	Test condition	Limits			Units
			Min.	Typ.	Max.	
Total						
Icc	Circuit current	No signal	—	30	45	mA
IDD	Circuit current	No signal	—	15	25	mA
Auto-Balance						
CPR	Capture range		—	5	—	dB
CER	Error collection		—	4	—	dB
Adaptive Matrix						
VoL	Output level accuracy relative to Cch	L,R,SLch output	-0.5	0	0.5	dB
MR	Matrix rejection	L,R,C,SLch output	25	40	—	dB
HRAM	Head room	THD=1%,	15	17	—	dB
THDAM	Total harmonic distortion	4ch mode,30kHz LPF	—	0.05	0.2	%
SNAM	S/N ratio	Rg=0 ,weighted CCIR/ARM 4ch mode	70	80	—	dB
Noise Sequencer						
Vno	Output noise level	L,R,C,SLch output	-15	-12.5	-10	dB
Vno	Noise level accuracy relative to Cch	L,R,SLch output	-0.5	0	0.5	dB
Modified B-type Noise Reduction (0dB reference is 300mVrms/100Hz at SOUT)						
VGNR	Gain between input and output	Vin=0dBd,f=100Hz	3.8	6.8	9.8	dB
DEC1	Decode character 1	Vin=0dBd,f=1.0kHz	-1.6	-0.1	1.4	dB
DEC2	Decode character 2	Vin=-15dBd,f=1.4kHz	-3.0	-1.5	0	
DEC3	Decode character 3	Vin=-40dBd,f=5.0kHz	-6.8	-5.3	-3.8	
THDNR	Total harmonic distortion	Vin=0dBd,f=1kHz,30kHz LPF	—	0.07	0.3	%
HRNR	Head room	THD=1%	15	17	—	dB
SNNR	S/N ratio	Rg=0 ,weighted CCIR/ARM	68	78	—	dB
Master Volume						
ATTmax	Maximum attenuation	ATT=- ,Vi=2Vrms	—	-95	-87	dB
ATTmin	Minimum attenuation	ATT=0dB,TRIM=0dB	-3.0	0	3.0	dB
VOLS1	Volume step1	ATT=0 to -40dB,TRIM=0dB	0.5	1.0	1.5	dB
VOLS2	Volume step2	ATT=-40 to -79dB,TRIM=0dB	0.2	1.0	1.8	dB
SNVOL	S/N ratio	ATT=- ,CCIR/ARM	85	95	—	dB
Trimmer						
TRIMmax	Maximum attenuation	TRIM=-31dB,VOLATT=0dB	-34	-31	-28	dB
TRIMmin	Minimum attenuation	TRIM=0dB,VOLATT=0dB	-3.0	0	3.0	dB
TRIMS	Teimmer step	VOLATT=0dB	0.6	1.0	1.4	dB
Line						
THDLN	Total harmonic distortion	30kHz LPF	—	0.002	0.05	%
SNLN	S/N ratio	DIN-AUDIO	95	100	—	dB
CTLN	Line cross-talk		70	80	—	dB
Zi	Input impedance		11	22	44	k

PRELIMINARY
 Notice ; This is not a final specification.
 some parametric limits are subject to change.

MITSUBISHI SOUND PROCESSORS
M62464FP
 Dolby Pro Logic Surround Decoder
 with Discrete 5.1ch Analog Input

(Ta=25 °C, Vcc=9V, VDD=5V, Vin=300mVrms unless otherwise noted)

Symbol	Parameter	Test conditions	Limits			Units	
			Min.	Typ.	Max.		
Digital Delay							
GvD	Voltage gain	DIN-DVOLUME, DVOL=0dB	-3.0	0	+3.0	dB	
Td	Delay time	Td=20.5ms	17.4	20.5	23.6	ms	
THDD	Total harmonic distortion	30kHz LPF	Td=20.5ms	—	0.5	0.9	%
			Td=51.2ms	—	1.2	2.2	
			Td=184ms	—	3.0	5.6	
NoD	Output noise voltage	Vin=0Vrms JIS-A	Td=20.5ms	—	-92	-80	dBV
			Td=51.2ms	—	-84	-70	
			Td=184ms	—	-80	-65	
Vomax	Maximum output voltage	THD=10%	0.7	1.0	—	Vrms	
LPFfc	LPF cut-off frequency	Td=15.4 to 51.2ms Gv=-3dB	6.0	7.0	8.0	kHz	
		Td=123, 184ms Gv=-3dB	—	3.0	—	kHz	
Feedback volume							
FBATT _{max}	Maximum attenuation	ATT=-	—	-70	-60	dB	
FBATT _{min}	Minimum attenuation	ATT=-3dB	-6.0	-3.0	0	dB	
FBVOLS	Volume step		1.5	3.0	4.5	dB	
Delay volume							
DLATT _{max}	Maximum attenuation	ATT=-	—	-70	-60	dB	
DLATT _{min}	Minimum attenuation	ATT=0dB	-3.0	0	3.0	dB	
DLVOLS	Volume step		1.5	3.0	4.5	dB	

PRELIMINARY
 Notice ; This is not a final specification.
 some parametric limits are subject to change.

SERIAL DATA CONTROL FORMAT

(1)Data Input Format

DATA is read at the rising edge of SCK, and loaded last 16 bits at the rising edge of REQ.

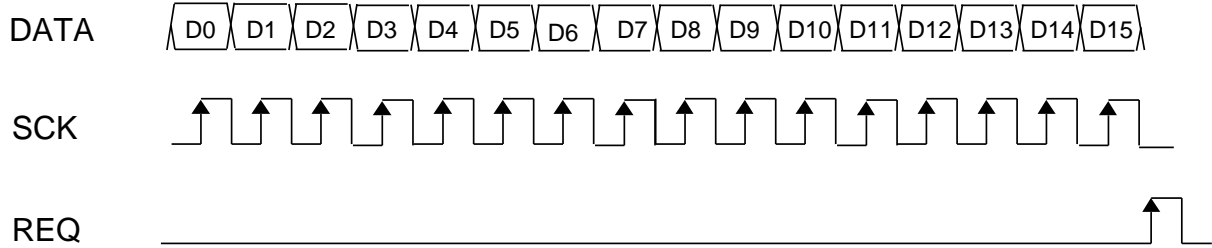

D0	D1	D2	D3	D4	D5	D6	D7	D8	D9	D10	D11	D12	D13	D14	D15
L	L	L	/	Mode Set		Pro Logic Mode	Center Mode	Auto-Balance	Noise Sequencer		L	H	Chip Address	L	H
		H	/	"L"	Delay Time		Space Surround Mode								
L	H	L	L	Delay Volume		Cch Volume			Chip Address	L	H				
		L	H	Feedback Volume		SLch Volume									
		H	L	/		SRch Volume									
		H	H	/	SW-VOL Set	SWch Volume									
H	L	L	/	Cch Trimmer			SWch Trimmer		Chip Address	L	H				
		H	/	SLch Trimmer			SRch Trimmer								
H	H	Test Mode (user inhibit)													

PRELIMINARY
 Notice ; This is not a final specification.
 some parametric limits are subject to change.

MITSUBISHI SOUND PROCESSORS
M62464FP
 Dolby Pro Logic Surround Decoder
 with Discrete 5.1ch Analog Input

(2)Control condition

Control Mode		Contents
1	Mode Set	Analog 5.1ch / Bypass / Pro Logic / Space Surround / Echo / Mute
2	Pro Logic Mode	4ch Pro Logic / 3ch stereo
3	Center Mode	Wide / Normal / Phantom / OFF
4	Delay Time	15.4, 20.5, 25.6, 29.2,51.2 ms (Short delay) 123, 184ms (Long delay)
5	Noise Sequencer	ON / OFF Lch / Rch / Cch / Sch
6	Auto-Balance	Input Auto-Balance ON / OFF
7	Space Surround Mode	L / R Output : Pro Logic / Space Surround Delay front mixing : Invert / Non-Invert Delay input : S' / L-R / (L+R)/2 BNR : ON / OFF Surround signal : Monaural / Pseudo Stereo
8	Delay Volume	0 to -18dB / 3dB step & -
9	Feedback Volume	-3 to -21dB / 3dB step & -
10	Master Volume	C,SL,SR,SW ch Master Volume 0 to -79dB / 1dB step & -
11	Trimmer	C,SL,SR,SW ch Trimmer 0 to -31dB /1dB step
12	SW Volume Set	SW Volume Through / Bypass
13	Chip Address	Input data effect or not

(3)Set Condition

a. Mode Set (D0="L",D1="L",D2="L")

D4	D5	D6	Condition
L	L	L	Analog 5.1ch
L	L	H	Bypass
L	H	L	Dolby Pro Logic Surround
L	H	H	Space Surround
H	L	L	Echo
H	L	H	Mute

PRELIMINARY
 Notice ; This is not a final specification.
 some parametric limits are subject to change.

MITSUBISHI SOUND PROCESSORS

M62464FP

Dolby Pro Logic Surround Decoder
 with Discrete 5.1ch Analog Input

b. Pro Logic Mode (D0="L",D1="L",D2="L")

D7	Condition
L	4ch Pro Logic
H	3ch Stereo

c. Center Mode (D0="L",D1="L",D2="L")

D8	D9	Condition
L	L	Wide
L	H	Normal
H	L	Phantom
H	H	OFF

d. Delay Time (D0="L",D1="L",D2="H")

D5	D6	D7	Delay Time	Sampling Frequency	LPF Cut-off Frequency
L	L	L	15.4msec	500kHz	7kHz
L	L	H	20.5msec	500kHz	
L	H	L	25.6msec	400kHz	
L	H	H	29.2msec	333kHz	
H	L	L	51.2msec	200kHz	
H	L	H	123msec	83.3kHz	3kHz
H	H	L	184msec	55.6kHz	

e. Noise Sequencer (D0="L",D1="L",D2="L")

D11	D12	D13	Condition	
L	-	-	Noise Sequencer OFF	
H	L	L	Noise Sequencer ON	Lch
	L	H		Rch
	H	L		Cch
	H	H		Sch

f. Auto-Balance (D0="L",D1="L",D2="L")

D10	Condition
L	Auto-Balance OFF
H	Auto-Balance ON

g. Space Surround Mode (D0="L",D1="L",D2="H")

L / R Output

D8	Condition
L	Pro Logic
H	Space Surround

Delay Mixing Polarity

D9	Mixing Polarity
L	L+Delay signal / R+Delay signal
H	L+Delay signal / R-Delay signal

Delay Input

D10	D11	Delay Input
L	X	S'
H	L	L-R
H	H	(L+R)/2

X : L or H

BNR

D12	BNR
L	OFF
H	ON

Surround Signal

D13	Surround Signal
L	Monaural
H	Pseudo Stereo

h. Delay Volume

(D0="L",D1="H",D2="L",D3="L")

D4	D5	D6	Volume
L	L	L	0dB
L	L	H	-3dB
L	H	L	-6dB
L	H	H	-9dB
H	L	L	-12dB
H	L	H	-15dB
H	H	L	-18dB
H	H	H	-

i. Feedback Volume

(D0="L",D1="H",D2="L",D3="H")

D4	D5	D6	Volume
L	L	L	-3dB
L	L	H	-6dB
L	H	L	-9dB
L	H	H	-12dB
H	L	L	-15dB
H	L	H	-18dB
H	H	L	-21dB
H	H	H	-

PRELIMINARY
 Notice ; This is not a final specification.
 some parametric limits are subject to change.

MITSUBISHI SOUND PROCESSORS

M62464FP

Dolby Pro Logic Surround Decoder
 with Discrete 5.1ch Analog Input

j. C,SL,SR,SW ch Volume (D0="L",D1="H")

Volume Level	D11	D10	D9	D8	D7
0 dB	L	L	L	L	L
-2 dB	L	L	L	L	H
-4 dB	L	L	L	H	L
-6 dB	L	L	L	H	H
-8 dB	L	L	H	L	L
-10 dB	L	L	H	L	H
-12 dB	L	L	H	H	L
-14 dB	L	L	H	H	H
-16 dB	L	H	L	L	L
-18 dB	L	H	L	L	H
-20 dB	L	H	L	H	L
-22 dB	L	H	L	H	H
-24 dB	L	H	H	L	L
-26 dB	L	H	H	L	H
-28 dB	L	H	H	H	L
-30 dB	L	H	H	H	H
-32 dB	H	L	L	L	L
-34 dB	H	L	L	L	H
-36 dB	H	L	L	H	L
-38 dB	H	L	L	H	H
-40 dB	H	L	H	L	L
-42 dB	H	L	H	L	H
-44 dB	H	L	H	H	L
-48 dB	H	L	H	H	H
-52 dB	H	H	L	L	L
-56 dB	H	H	L	L	H
-60 dB	H	H	L	H	L
-64 dB	H	H	L	H	H
-68 dB	H	H	H	L	L
-72 dB	H	H	H	L	H
-76 dB	H	H	H	H	L
-	H	H	H	H	H

Volume Level	D13	D12
0 dB	L	L
-1 dB	L	H
-2 dB	H	L
-3 dB	H	H

SW Volume Setting

D6 (D0="L",D1="H",D2="H",D3="H")	Condition	SWBP-SW
L	Bypass Volume	2
H	Through Volume	1

PRELIMINARY
 Notice ; This is not a final specification.
 some parametric limits are subject to change.

MITSUBISHI SOUND PROCESSORS

M62464FP

Dolby Pro Logic Surround Decoder
 with Discrete 5.1ch Analog Input

k. C,SL,SR,SW ch Trimmer (D0="H",D1="L")

Trimmer Level	D8	D7	D6	D5	D4
	D13	D12	D11	D10	D9
0 dB	L	L	L	L	L
-1 dB	L	L	L	L	H
-2 dB	L	L	L	H	L
-3 dB	L	L	L	H	H
-4 dB	L	L	H	L	L
-5 dB	L	L	H	L	H
-6 dB	L	L	H	H	L
-7 dB	L	L	H	H	H
-8 dB	L	H	L	L	L
-9 dB	L	H	L	L	H
-10 dB	L	H	L	H	L
-11 dB	L	H	L	H	H
-12 dB	L	H	H	L	L
-13 dB	L	H	H	L	H
-14 dB	L	H	H	H	L
-15 dB	L	H	H	H	H
-16 dB	H	L	L	L	L
-17 dB	H	L	L	L	H
-18 dB	H	L	L	H	L
-19 dB	H	L	L	H	H
-20 dB	H	L	H	L	L
-21 dB	H	L	H	L	H
-22 dB	H	L	H	H	L
-23 dB	H	L	H	H	H
-24 dB	H	H	L	L	L
-25 dB	H	H	L	L	H
-26 dB	H	H	L	H	L
-27 dB	H	H	L	H	H
-28 dB	H	H	H	L	L
-29 dB	H	H	H	L	H
-30 dB	H	H	H	H	L
-31 dB	H	H	H	H	H

When (Trimmer level)+(Volume level) is less than -87dB, attenuation level is set to -87dB.

PRELIMINARY
 Notice ; This is not a final specification.
 some parametric limits are subject to change.

MITSUBISHI SOUND PROCESSORS
M62464FP
 Dolby Pro Logic Surround Decoder
 with Discrete 5.1ch Analog Input

I. Chip Address

D14	D15	Data Read
L	H	Enable
Others		Unable

Relation between mode setting and switch condition

Mode Setting	Pro Logic Mode (D0=L,D1=L,D2=L) D7	Space Surround Mode (D0=L,D1=L,D2=H)					Switch Condition									
		D8	D10	D11	D12	D13	L-SW	R-SW	C-SW	SL-SW	SR-SW	SW-SW	DI-SW	DO-SW	BNR-SW	
Analog 5.1ch	X	X	X	X	X	X	1	1	1	1	1	1	4	2	3	
Bypass	L	X	L	X	L	L	2	2	2	2	2	2	1	1	2	
			L	H	H	3				3	2		1			
			H	H	X	H				3	3		3		3	
Dolby Pro Logic Surround	L	X	X	X	X	X	4	4	2	2	2	2	1	1	1	
	H														3	
Space Surround	X	L	L	X	L	L	4	4	2	2	2	2	1	1	2	
			H	H	L	H				H	3		3		3	3
Echo	X	X	X	X	X	X	2	2	1	1	1	2	4	2	3	
Mute	X	X	X	X	X	X	5	5	1	1	1	2	4	2	3	

X: L or H

At Bypass or Space Surround Mode, the condition of SL-SW,SR-SW,DI-SW and BNR-SW depend on D7,D10,D11,D12 and D13.

- SL-SW,SR-SW : depend on D13 -----> *1
- DI-SW : depend on D10 and D11----->*2
- BNR-SW : depend on D7 and D12-----*3

At Space Surround Mode, the condition of L-SW and R-SW depend on D8.----->*4

(4)Data Timing

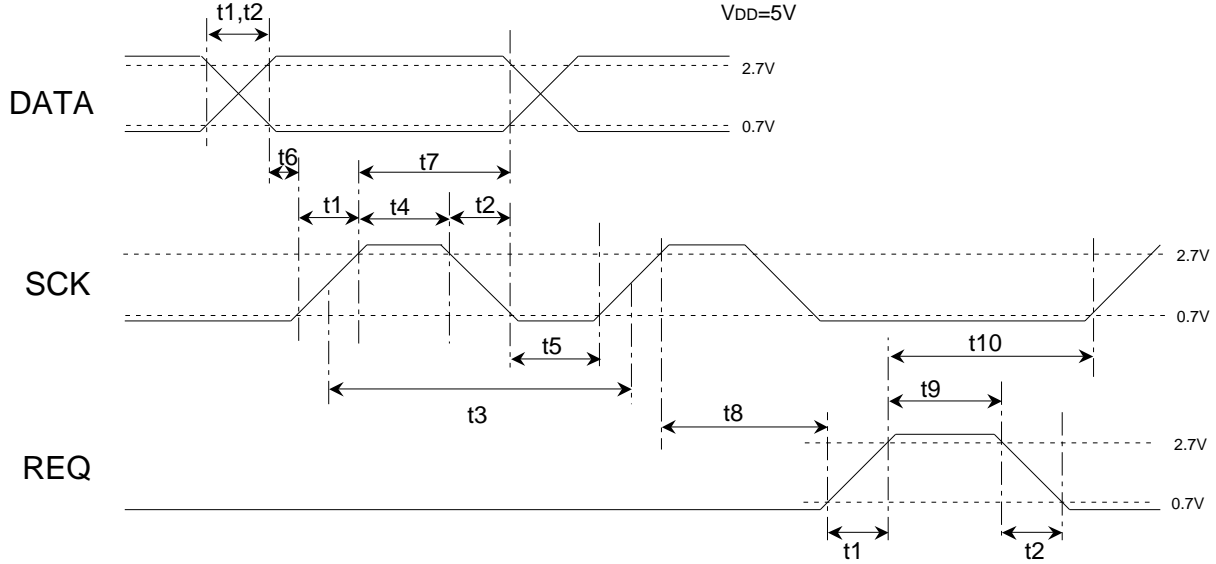

Symbol	Name	Min	Typ	Max	Units
t1	Signal rise time	—	—	0.5	μs
t2	Signal fall time	—	—	0.5	μs
t3	SCK clock width	2	—	—	μs
t4	SCK "H" pulse width	0.8	—	—	μs
t5	SCK "L" pulse width	0.8	—	—	μs
t6	DATA setup time	0.8	—	—	μs
t7	DATA hold time	0.8	—	—	μs
t8	REQ rise hold time	1.6	—	—	μs
t9	REQ "H" pulse width	0.8	—	—	μs
t10	SCK setup time	1.6	—	—	μs

PRELIMINARY
 Notice ; This is not a final specification.
 some parametric limits are subject to change.

MITSUBISHI SOUND PROCESSORS

M62464FP

Dolby Pro Logic Surround Decoder
 with Discrete 5.1ch Analog Input

Mode Example

(1) Analog 5.1ch

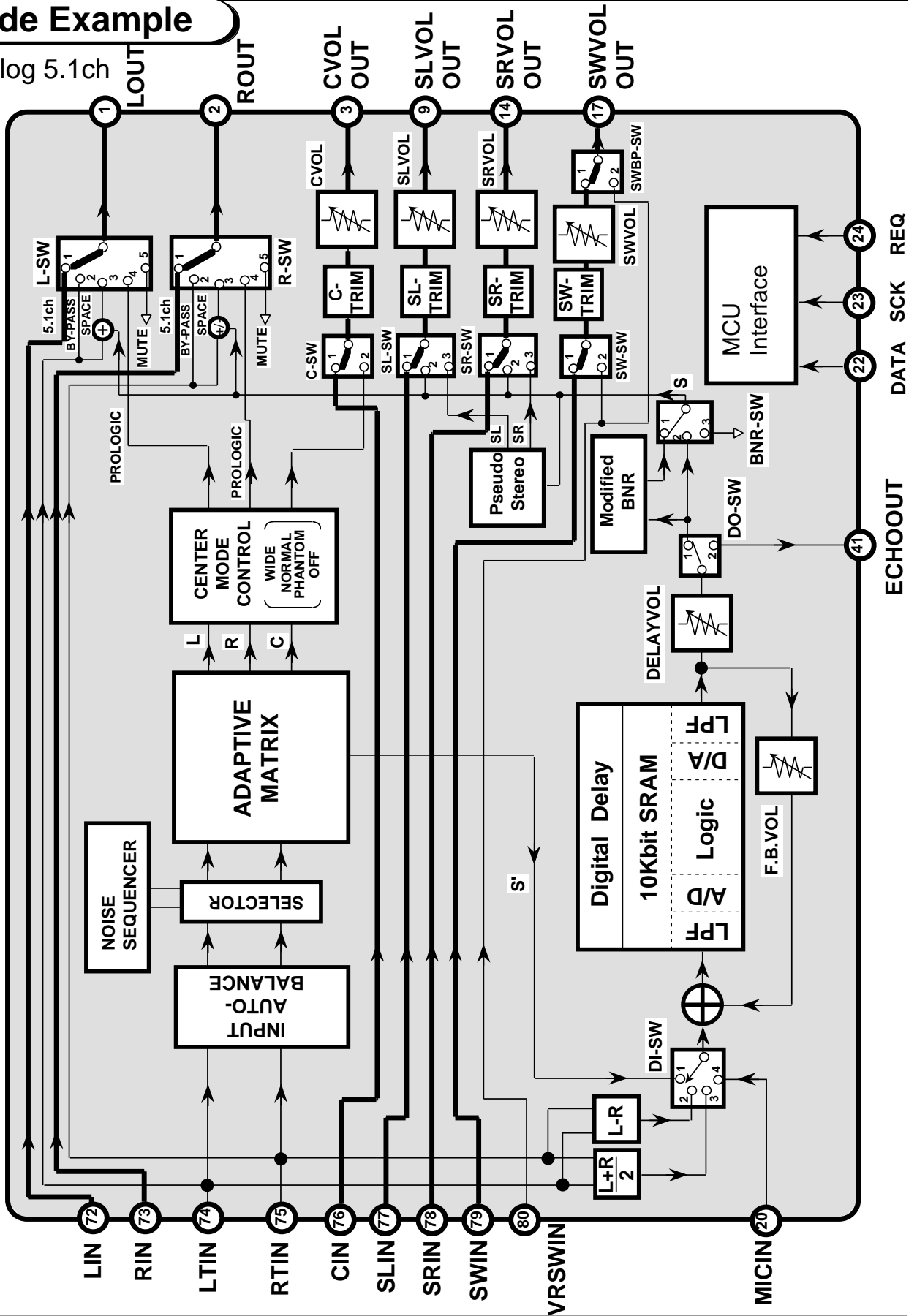

PRELIMINARY
 Notice ; This is not a final specification.
 some parametric limits are subject to change.

MITSUBISHI SOUND PROCESSORS

M62464FP

Dolby Pro Logic Surround Decoder
 with Discrete 5.1ch Analog Input

(2)Pro Logic Surround

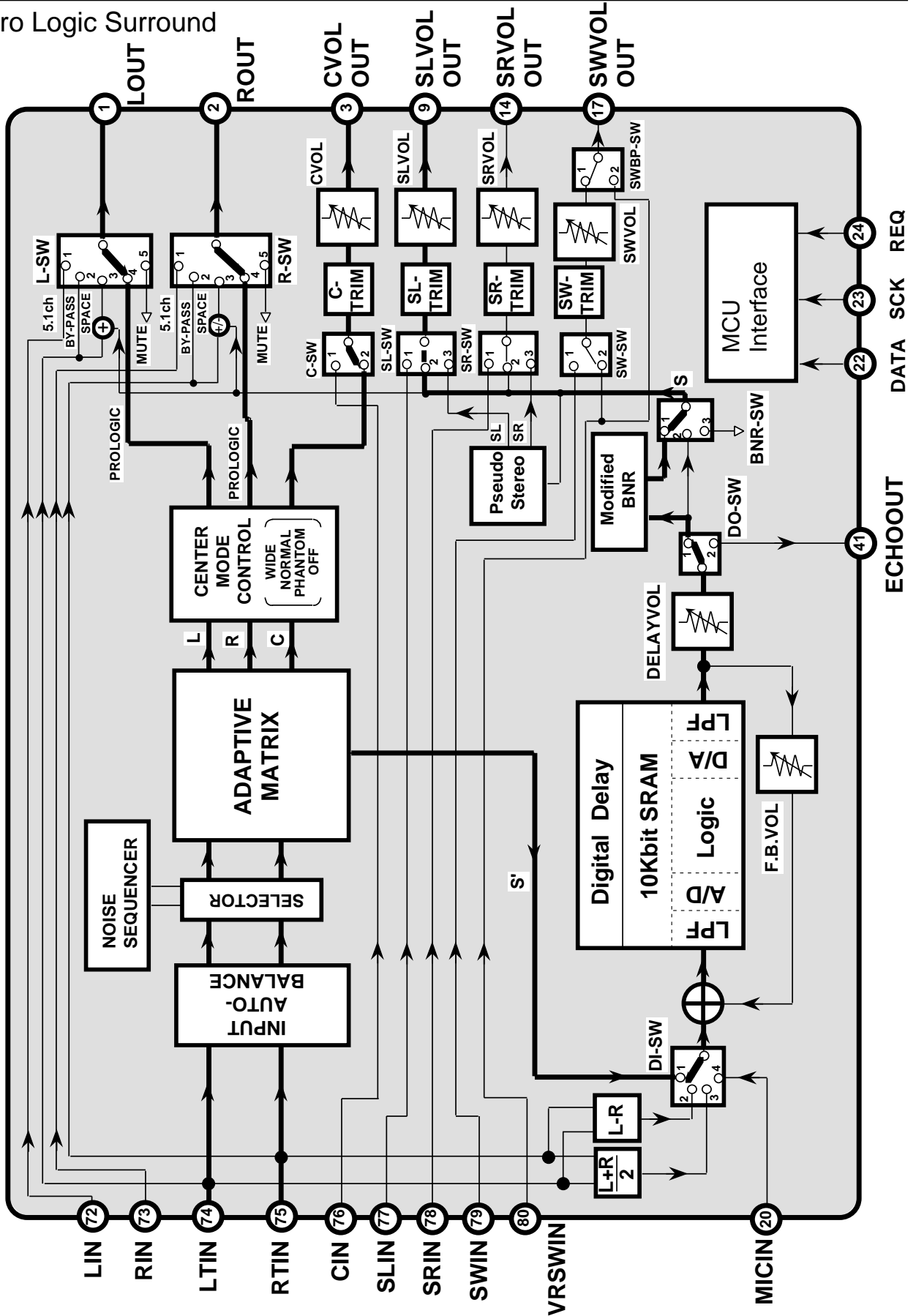

PRELIMINARY

Notice ; This is not a final specification.
some parametric limits are subject to change.

MITSUBISHI SOUND PROCESSORS

M62464FP

Dolby Pro Logic Surround Decoder
with Discrete 5.1ch Analog Input

(3)Space Surround

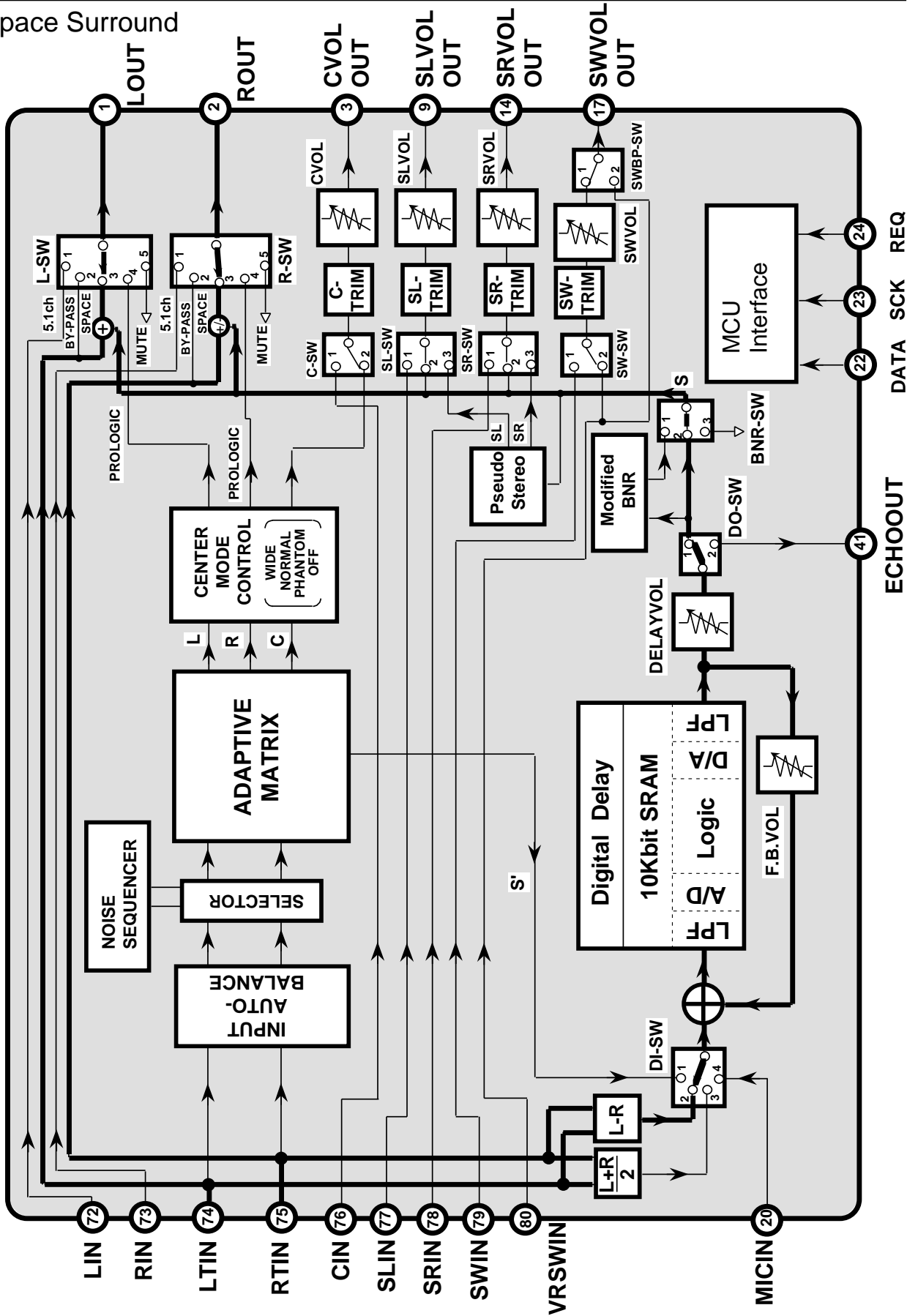

PRELIMINARY

Notice ; This is not a final specification.
some parametric limits are subject to change.

MITSUBISHI SOUND PROCESSORS

M62464FP

Dolby Pro Logic Surround Decoder
with Discrete 5.1ch Analog Input

(4)Echo

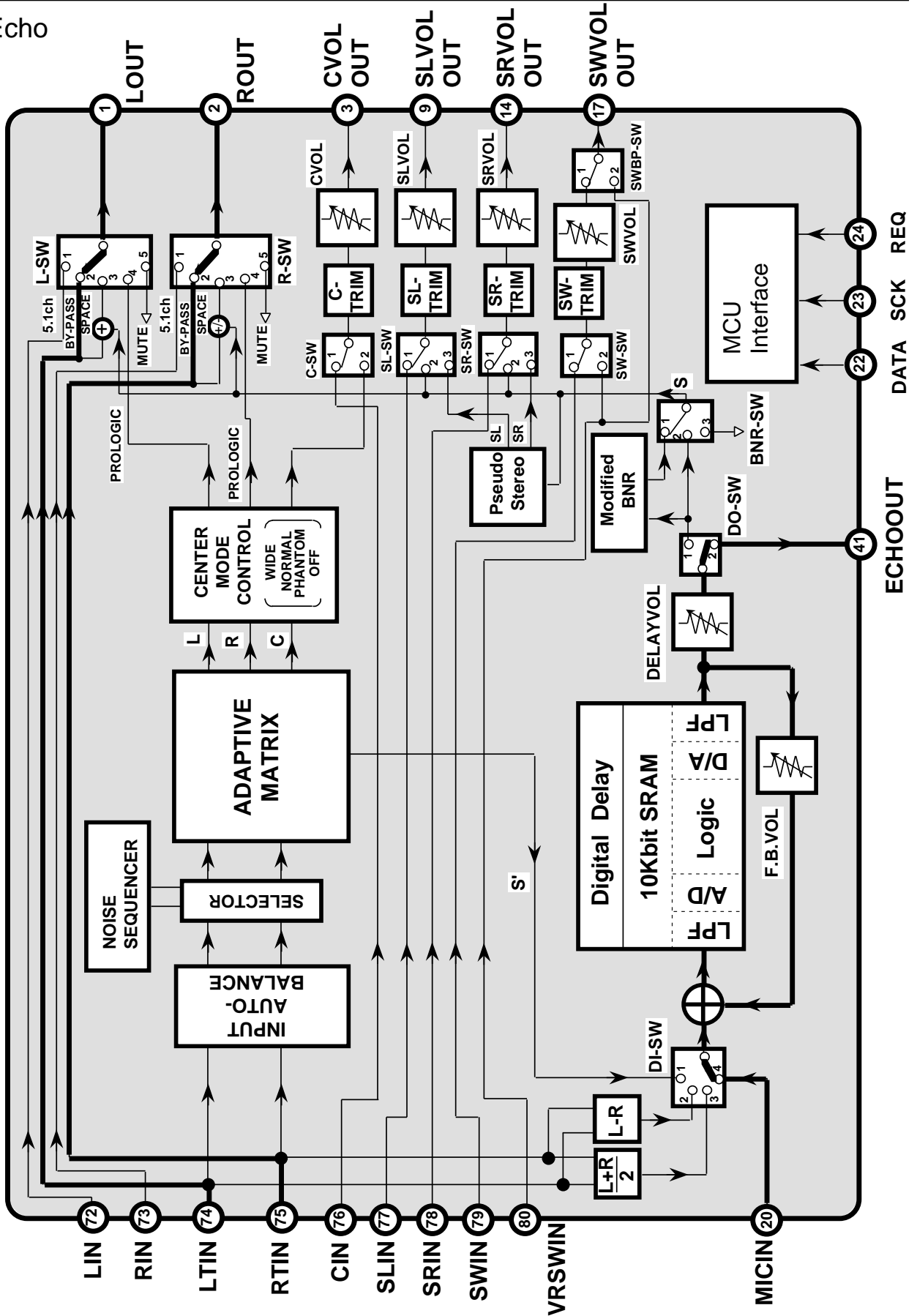

PRELIMINARY
 Notice ; This is not a final specification.
 some parametric limits are subject to change.

Level Diagram

(1)Dolby Pro Logic Surround Mode

Cch

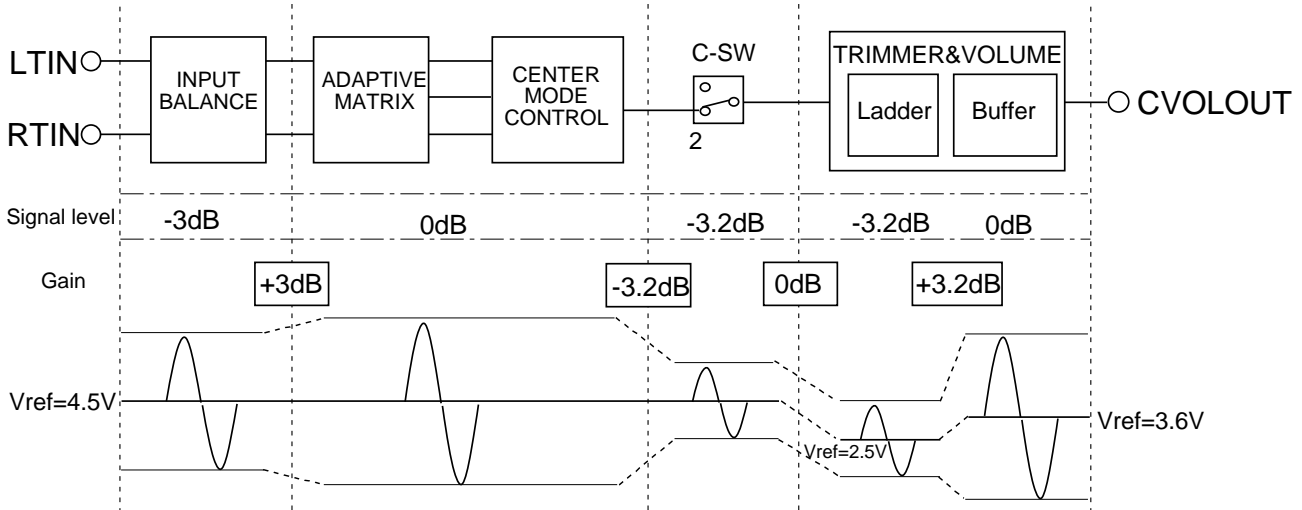

Sch

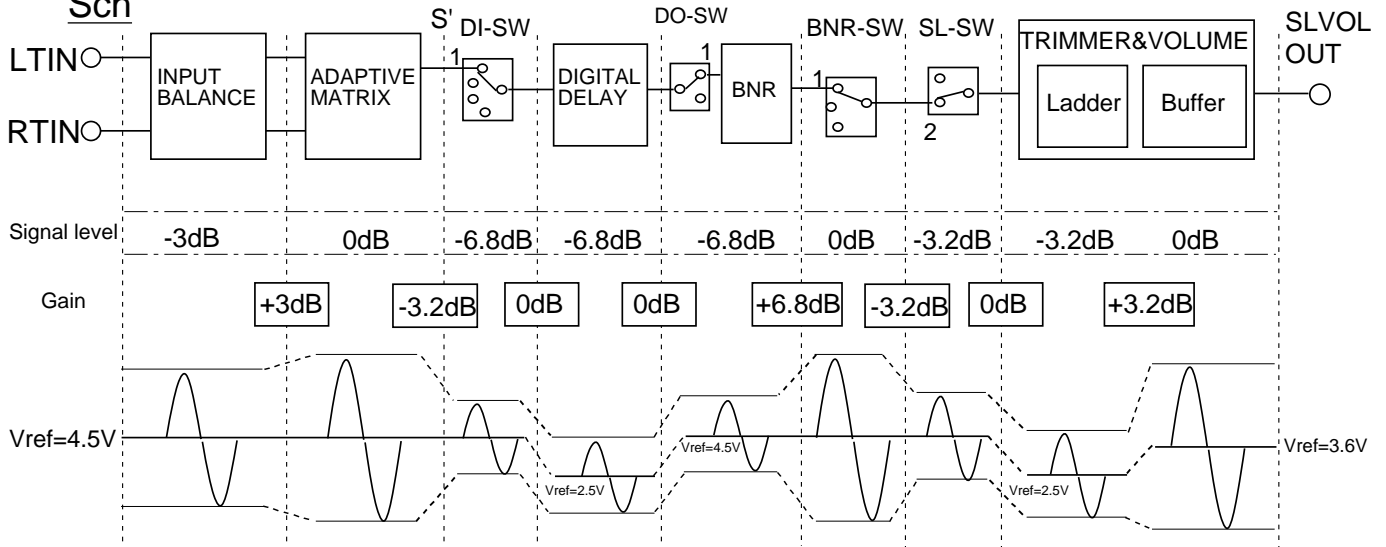

Lch,Rch

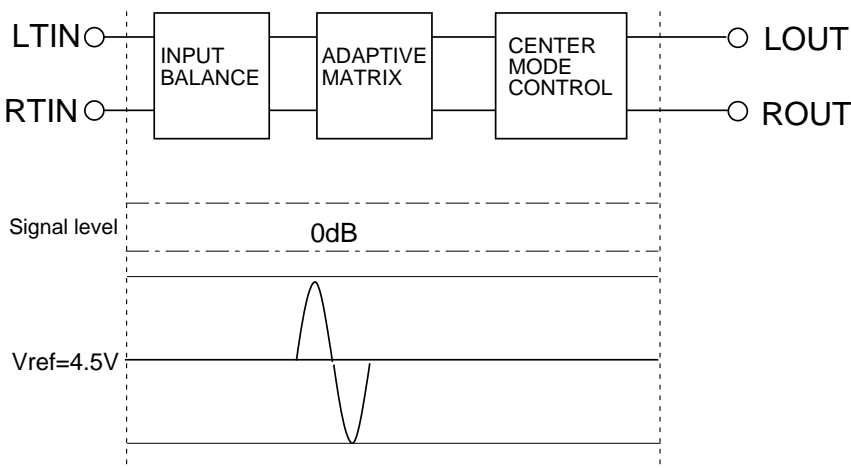

Signal level : 0dB=300mVrms(typ.)

PRELIMINARY
 Notice ; This is not a final specification.
 some parametric limits are subject to change.

MITSUBISHI SOUND PROCESSORS
M62464FP
 Dolby Pro Logic Surround Decoder
 with Discrete 5.1ch Analog Input

(2) Analog 5.1ch

C,SL,SR,SW ch

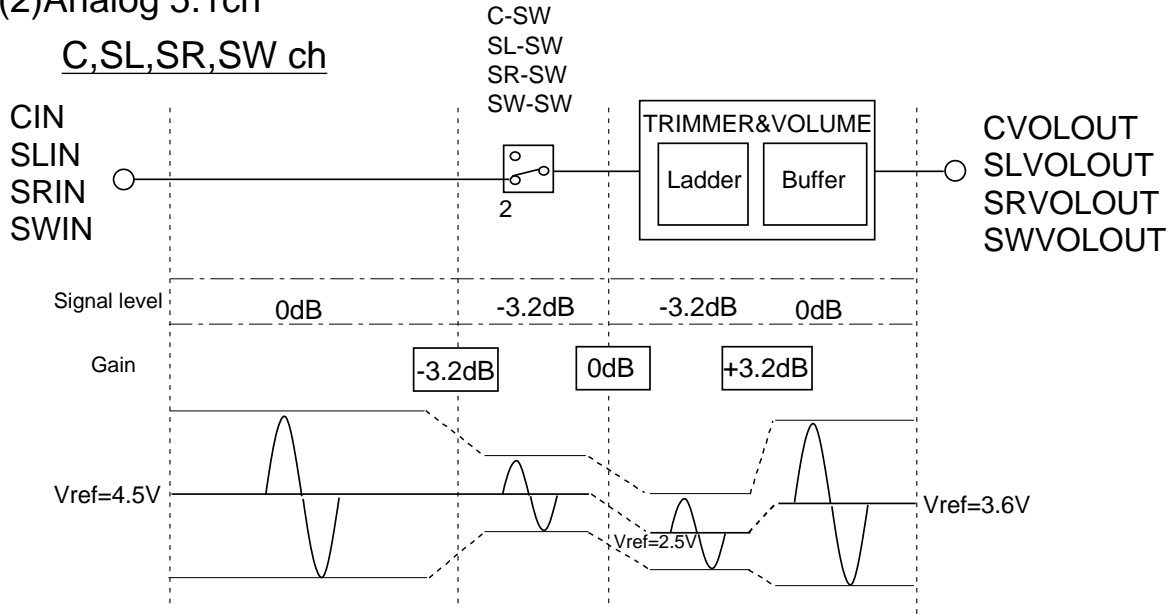

(3) Space Surround Mode

Delay Signal

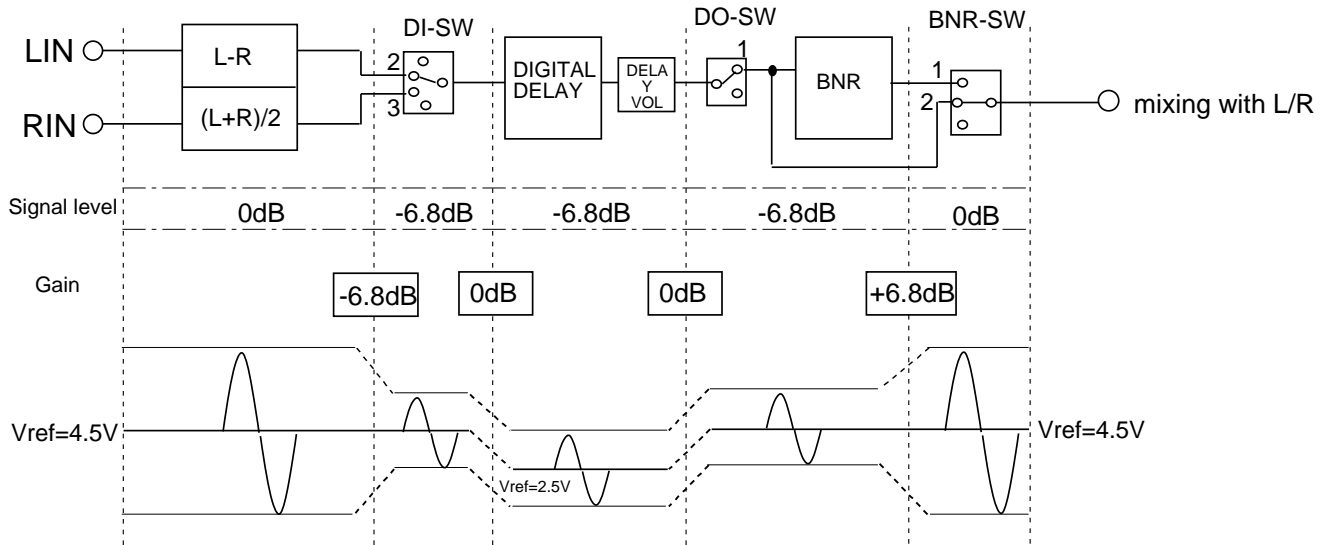

(4) Echo Mode

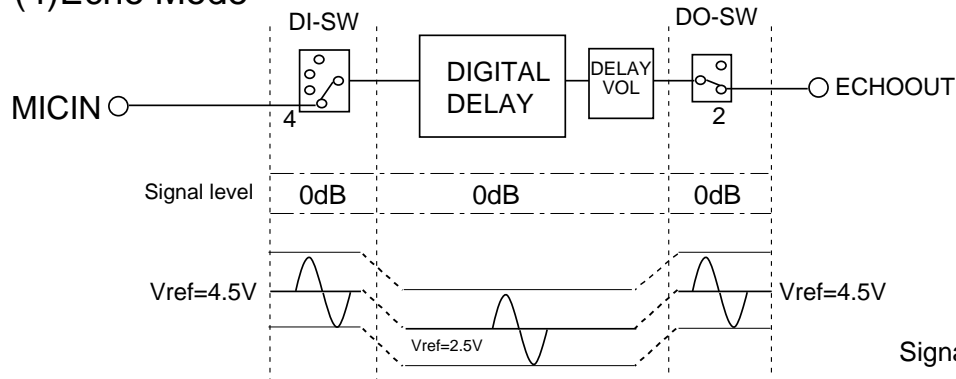

Signal level : 0dB=300mVrms(typ.)

Notice

Relation AV_{CC} and DV_{DD} at power supply
Digital V_{DD} must be supplied between 0.7 and 1.3 seconds after
analog V_{CC} is supplied.

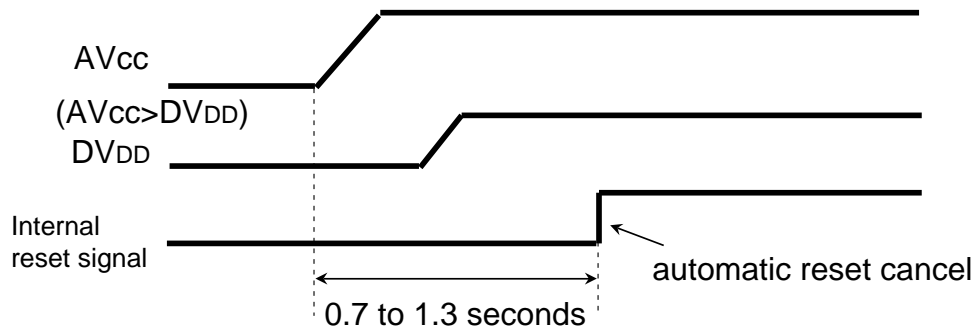

PRELIMINARY
 Notice : This is not a final specification.
 some parametric limits are subject to change.

MITSUBISHI SOUND PROCESSORS
M62464FP
 Dolby Pro Logic Surround Decoder
 with Discrete 5.1ch Analog Input

APPLICATION EXAMPLE

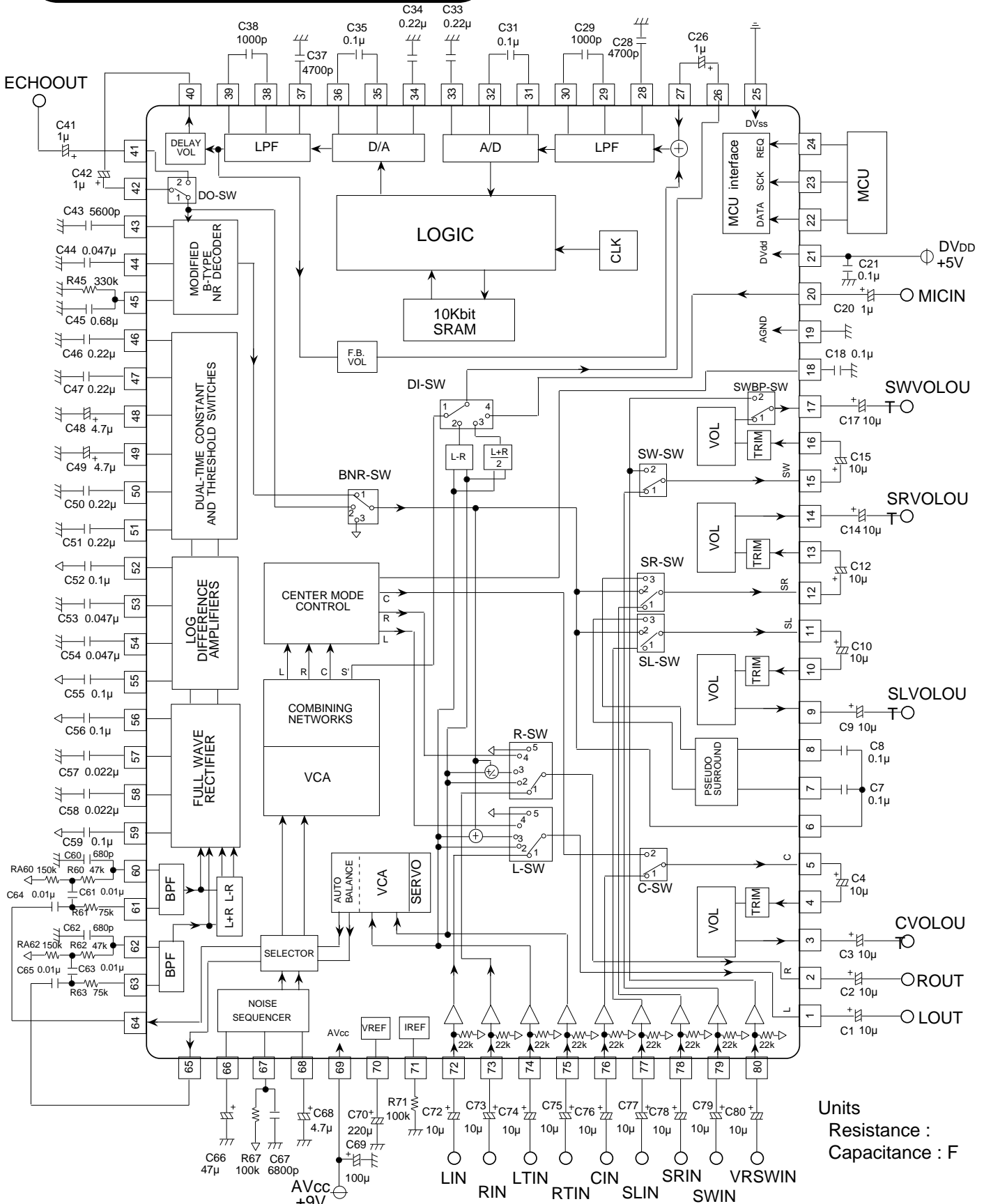

PRELIMINARY
 Notice ; This is not a final specification.
 some parametric limits are subject to change.

MITSUBISHI SOUND PROCESSORS

M62464FP

**Dolby Pro Logic Surround Decoder
 with Discrete 5.1ch Analog Input**

EXTERNAL PARTS LIST

Parts No.	Values	Unit	Tol.	Parts No.	Values	Unit	Tol.
C1	10	μF		C57	0.022	μF	5%
C2	10	μF		C58	0.022	μF	5%
C3	10	μF		C59	0.1	μF	20%
C4	10	μF		C60	680	pF	5%
C7	0.1	μF		C61	0.01	μF	5%
C8	0.1	μF		C62	680	pF	5%
C9	10	μF		C63	0.01	μF	5%
C10	10	μF		C64	0.01	μF	5%
C12	10	μF		C65	0.01	μF	5%
C14	10	μF		C66	47	μF	
C15	10	μF		C67	6800	pF	5%
C17	10	μF		C68	4.7	μF	10%
C18	0.1	μF	10%	C69	100	μF	
C20	1.0	μF		C70	220	μF	
C21	0.1	μF		C72	10	μF	
C26	1.0	μF		C73	10	μF	
C28	4700	pF	5%	C74	10	μF	
C29	1000	pF	5%	C75	10	μF	
C31	0.1	μF	5%	C76	10	μF	
C33	0.22	μF	5%	C77	10	μF	
C34	0.22	μF	5%	C78	10	μF	
C35	0.1	μF	5%	C79	10	μF	
C37	4700	pF	5%	C80	10	μF	
C38	1000	pF	5%				
C41	1.0	μF					
C42	1.0	μF					
C43	5600	pF	5%				
C44	0.047	μF	5%	R45	330	k	10%
C45	0.68	μF	10%	R60	47	k	5%
C46	0.22	μF	10%	RA60	150	k	5%
C47	0.22	μF	10%	R61	75	k	5%
C48	4.7	μF	20%	R62	47	k	5%
C49	4.7	μF	20%	RA62	150	k	5%
C50	0.22	μF	10%	R63	75	k	5%
C51	0.22	μF	10%	R67	100	k	1%
C52	0.1	μF	20%	R71	100	k	5%
C53	0.047	μF	5%				
C54	0.047	μF	5%				
C55	0.1	μF	20%				
C56	0.1	μF	20%				