

DATE OF ISSUE : 2008. 05. 22

# SPECIFICATION

MODEL : SLHNNWH531N0S0QRC5

[Rank : (S0), (Q0, R0), (F2, G2, H2)]

HIGH POWER LED - SUNNIX

CUSTOMER : CML

SAMSUNG ELECTRO-MECHANICS		
DRAWN	CHECKED	APPROVED

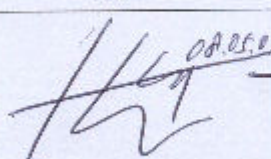
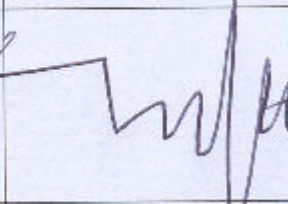
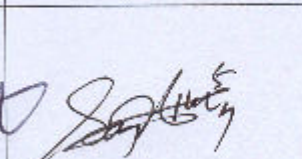
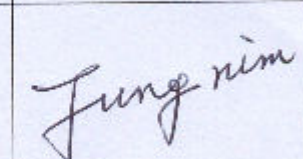
SAMSUNG ELECTRO-MECHANICS			
DRAWN	CHCKED(Sales)	CHECKED(Quality)	APPROVED
			

**SAMSUNG ELECTRO-MECHANICS CO.,LTD.**  
314, MAETAN3-DONG, YEONGTONG-GU,  
SUWON, GYUNGGI-DO, KOREA,442-743

## Contents

1. Product Outline-----	3
2. Absolute Maximum Rating-----	3
3. Characteristics -----	3
4. Chromaticity Diagram-----	4
5. Typical Characteristic Graph -----	5
6. Outline Drawing And Dimension -----	6
7. Package Structure -----	7
8. Reliability Test Items And Conditions -----	8
9. Solder Conditions -----	9
10. Taping Dimension -----	10
11. Reel Packing Structure -----	11
12. Label Structure -----	12
13. Lot Number -----	12
14. Precaution For use -----	14
15. Hazard Substance Analysis -----	15
16. Revision History -----	18

## Product Outline

### 1) Feature

1. Plastic Molded L/Frame type ( 7.0mm \* 7.0mm \* t 2.0mm)
2. Beam Angle (  $\Delta\theta$  : 120 ° )
3. High Power/Brightness Chip & Long Time Reliability

### 2) Applications

- Automotive, Illumination etc.

## Absolute Maximum Rating<sup>1),2)</sup>

- Operation Forward Current ..... 700 mA
- Peak Pulsed Forward Current ..... 800 mA  
(Duty 1/10 Pulse Width 10msec)
- Reverse Voltage ..... 5V
- Thermal Resistance(Rth)<sup>3)</sup> .....  $\cong$  8 °C/W
- LED Junction Temperature ( T<sub>j</sub> ) ..... 125°C
- Operating Temperature Range ( T<sub>opr</sub> ) ..... -35°C ~ 85°C
- Storage Temperature Range ( T<sub>stg</sub> ) ..... -40°C ~ 110°C

## Characteristics<sup>1),2)</sup>

### Electrical Characteristics

( T<sub>j</sub> : 25°C )

Item	Rank	Symbol	Min.	Typ.	Max.	Unit	Conditions
Forward Voltage	S0	V <sub>F</sub>	3.2	-	4.5	V	I <sub>F</sub> =700mA
Reverse Voltage	-	V <sub>R</sub>	0.5	-	2.0	V	I <sub>R</sub> =10mA

### Chromaticity Coordinate

Rank	CCx					CCy				CCT [K]	Condition
QR	Q0	0.3128	0.3250	0.3200	0.3011	0.2864	0.2981	0.3600	0.3407	6,000~7,000	I <sub>F</sub> =700mA
	R0	0.3250	0.3428	0.3471	0.3200	0.2981	0.3138	0.3818	0.3600	5,000~6,000	

### Luminous Flux

Rank	Symbol	Min.	Max.	Unit	Conditions
C5	F2	100	120	lm	I <sub>F</sub> =700mA
	G2	120	140		
	H2	140	160		

### Remarks)

- 1) Tolerance : V<sub>F</sub> :  $\pm$  0.1V,  $\Phi_v$  :  $\pm$ 10%, CCx CCy :  $\pm$ 0.02
- 2) These specifications can be modified without any notices.
- 3) Proper thermal managements should be considered into a circuit design

## ■ Chromaticity Diagram

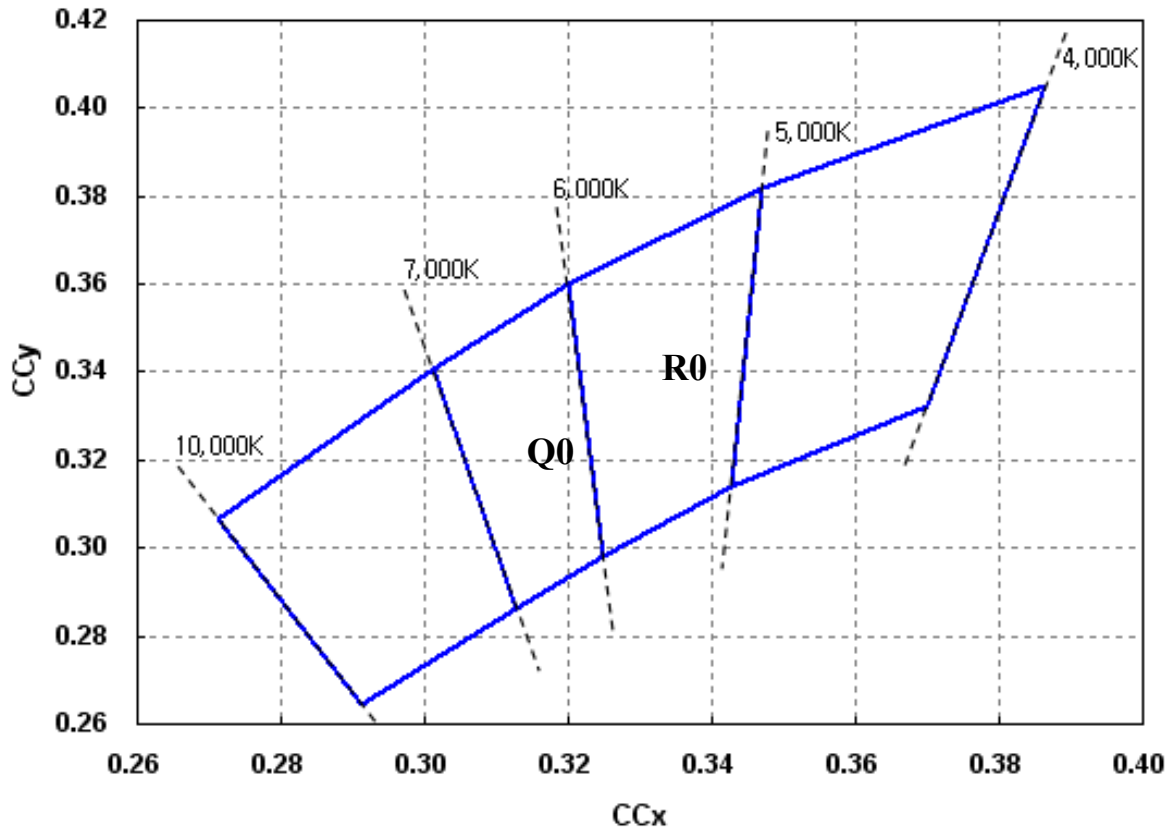

※ Approved Rank

V <sub>F</sub>	CIE	Im
S0	Q0, R0	F2, G2, H2

# Typical Characteristics Graph

Relative Luminous Flux vs Forward Current

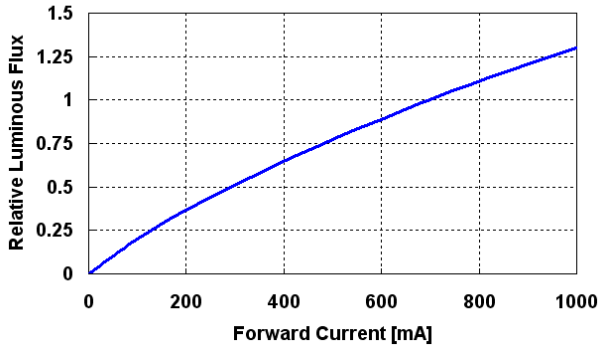

Forward Current vs Forward Voltage

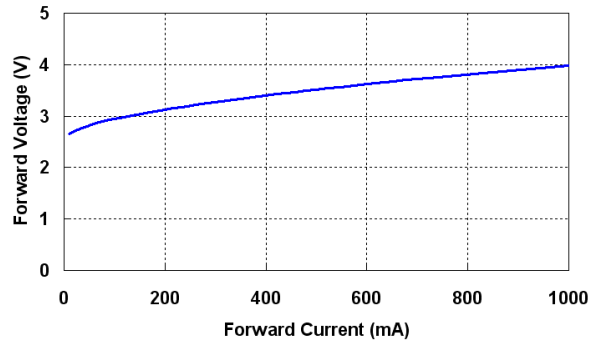

Spectrum Distribution

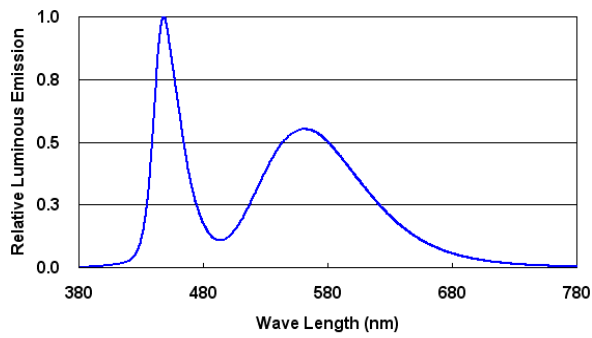

Radiation Diagram

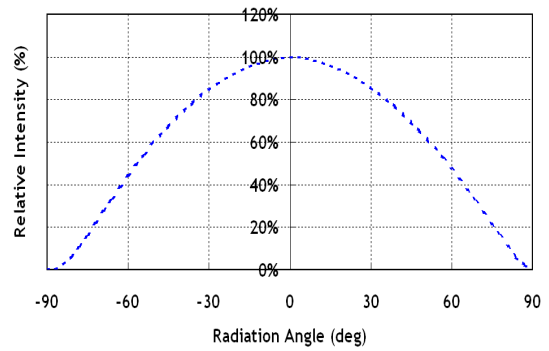

Derating Curve for 700mA (White)

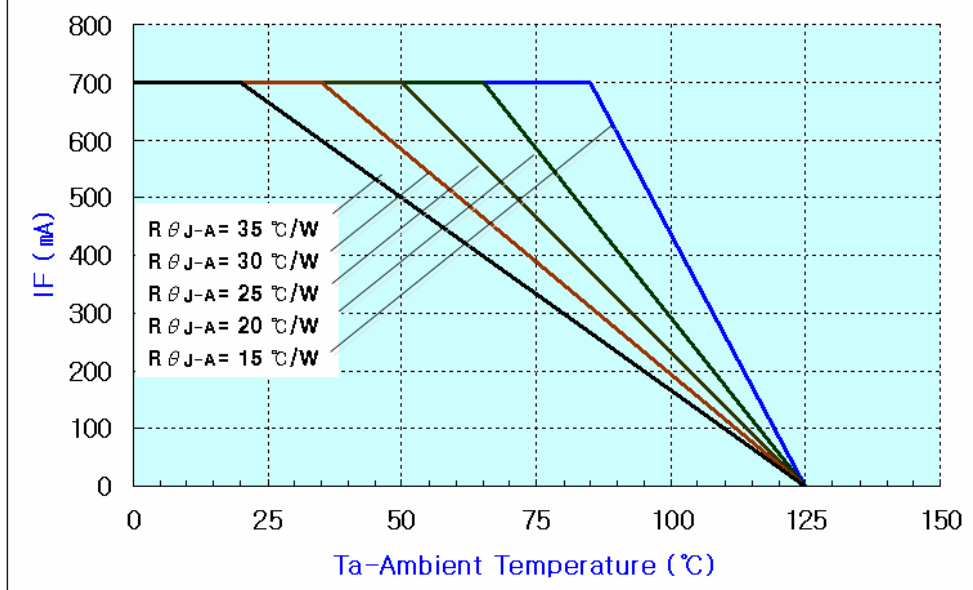

## Outline Drawing and Dimension

Unit:mm

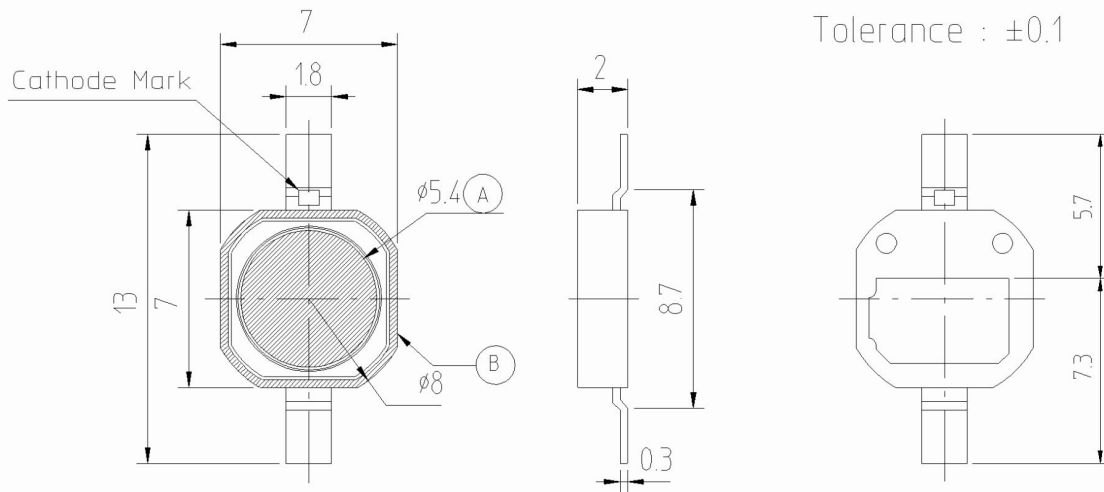

### Pick and Place

1. Do not place pressure on the encapsulating resin ("A").  
It is recommended to use a pick & place nozzle with inside diameter of 5.8mm.
2. The maximum compressing force is 15N on the polymer ("B").

### Circuit

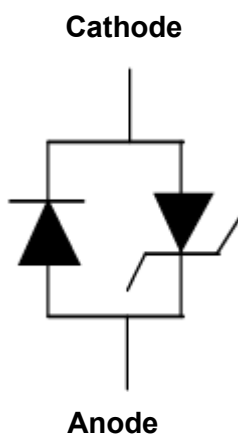

### Solder Pattern for Surface Mount

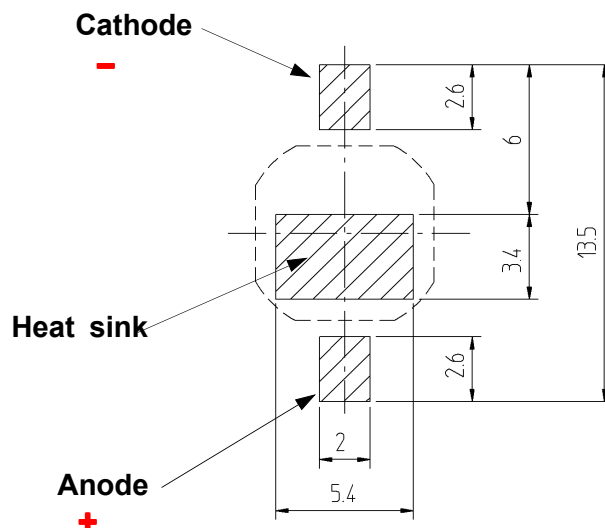

### Remarks)

Make sure the heat sink is electrically connected to the Anode.  
Heat sink is to be soldered, If not, use the heat conductive adhesive

## Package Structure

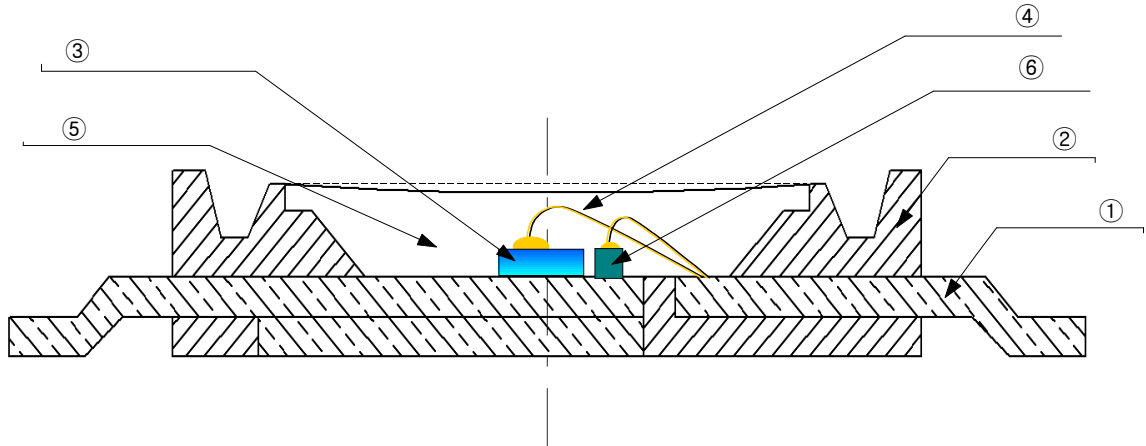

No	Item	Material
①	FRAME	Copper Frame(Silver plated)
②	PACKAGE	Heat-resistant Polymer
③	LED CHIP	SiC
④	WIRE	Gold Wire
⑤	RESIN	Silicone Resin
⑥	ZENER DIODE	Si

## Reliability Test Items and Conditions

### 1) Test Items

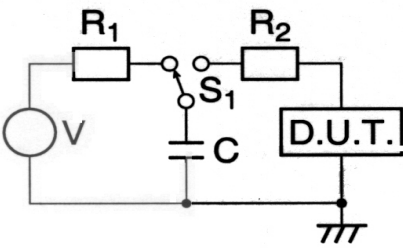
Test Item	Test Conditions	Test Hours/Cycles	Sample No
Room Temperature life test	25 °C, If=Max DC <sup>1)</sup>	1,000 h	22
High Temperature humidity life test	85 °C, 85 % RH, If=Max DC <sup>1)</sup>	1,000 h	22
High Temperature life test	85 °C, If=Max DC <sup>1)</sup>	1,000 h	22
Low Temperature life test	-40 °C, If=Max DC <sup>1)</sup>	1,000 h	22
High Temperature Storage	110 °C	1,000 h	11
Low Temperature Storage	-40 °C	1,000 h	11
Thermal Shock	-40 / 120 °C, each 30 min	200 cycles	22
Temperature humidity Cycle On/Off test	-40 / 85 °C, each 20 min, 100 min transfer Power On/off each 5 min, DC 350 mA	100 cycles	22
Reflow (Pb-Free)	Peak 260±5 °C for 10sec	3 times	11
ESD(HBM)	 <p>R1:10MΩ , R2:1.5KΩ , C:100pF</p>	3 times (± 5kV)	5

1) Max. DC current depending on maximum current derating curve.

### 2) Criteria for Judging the Damage

Item	Symbol	Test Condition	Limit	
			Min	Max
Forward Voltage	V <sub>F</sub>	I <sub>F</sub> = 700 mA	-	U.S.L.*1.2
Luminous Flux	Φ <sub>v</sub>	I <sub>F</sub> = 700 mA	L.S.L.*0.5	-

\* USL : Upper Standard Level      LSL : Lower Standard Level



## ■ Solder Conditions

Reflow Frequency : 2 times max.

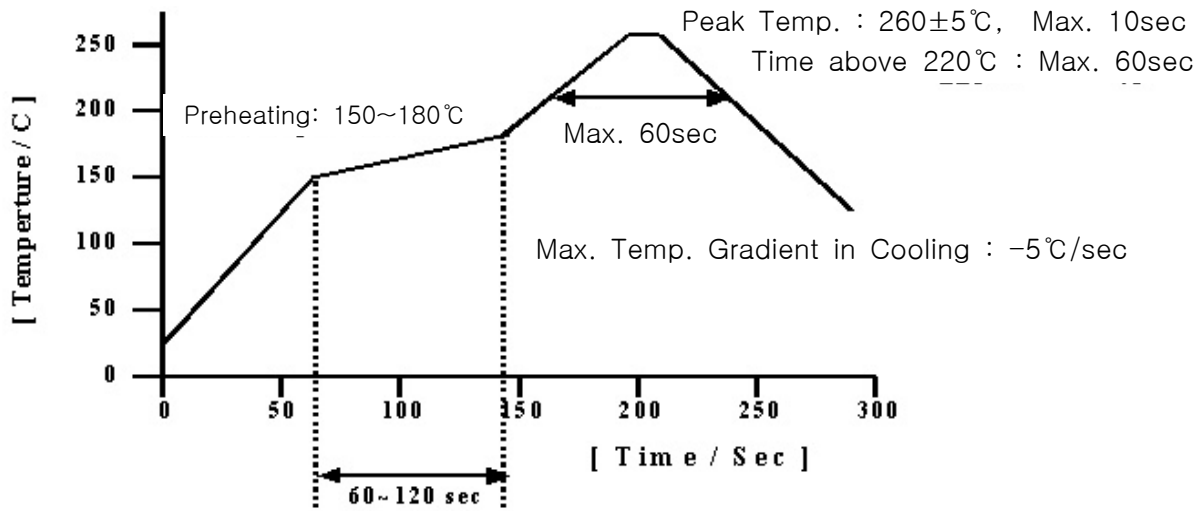

### 2) For Manual Soldering

Not more than 5 seconds @MAX300°C, under soldering iron.

## ■ Taping Dimension

### 1. Carrier Tape

Cathode



Anode

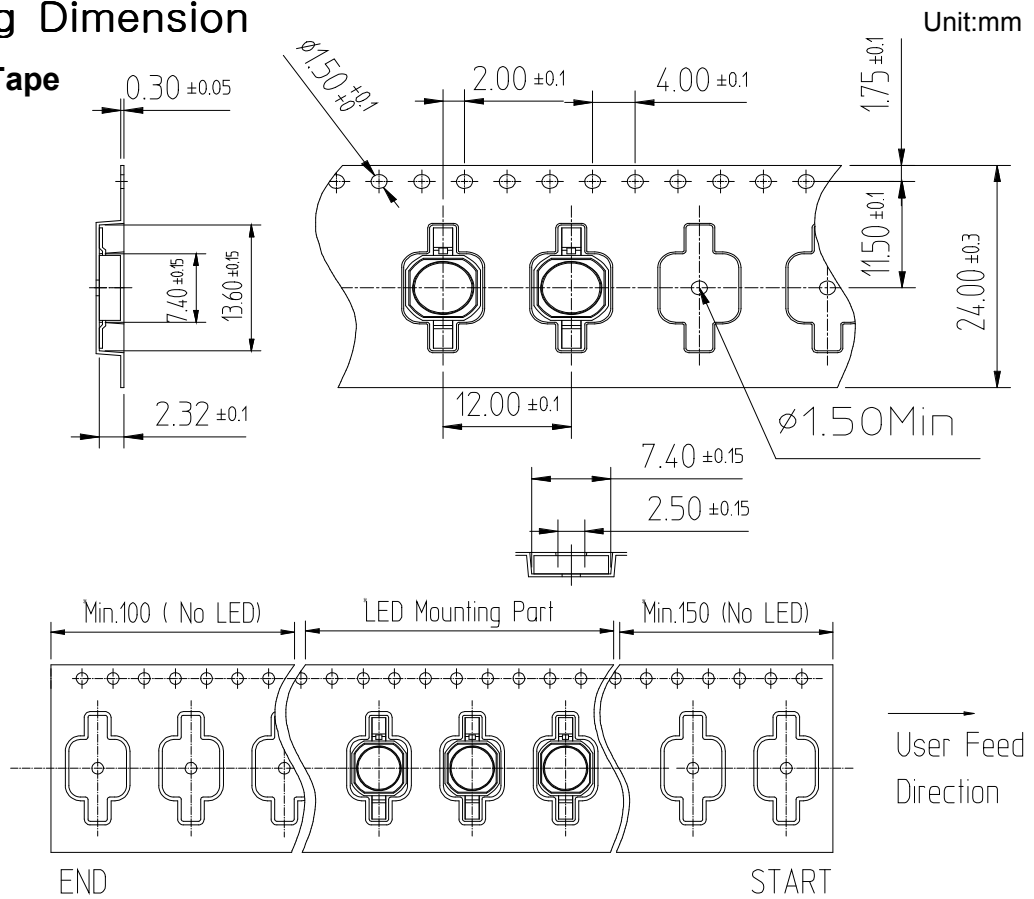

### 2. Reel

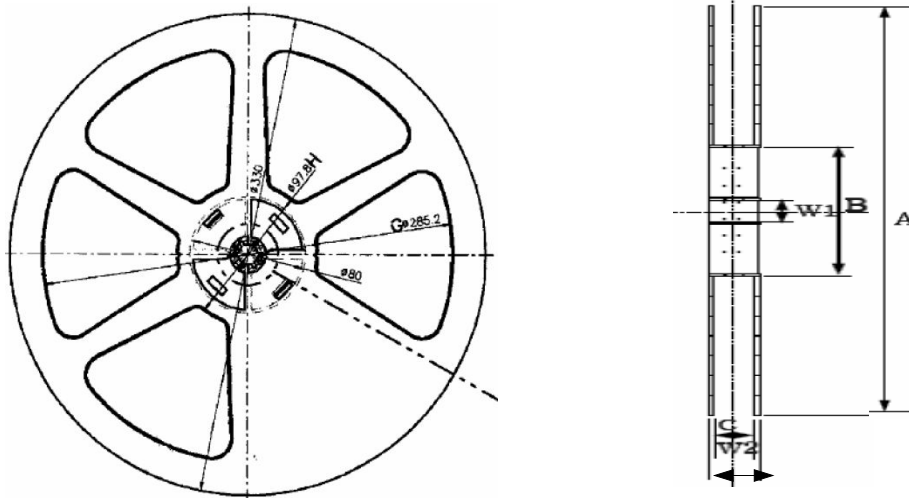

Symbol	A	B	C	W1	W2
Dimension(mm)	330 ± 1	80 ± 1	25 ± 0.5	13 ± 0.3	29.5 ± 1

- (1) Quantity : 2,000 Pcs / 13" Reel.
- (2) Cumulative Tolerance : Cumulative Tolerance/10 pitches to be ±0.2mm
- (3) Adhesion Strength of Cover Tape : Adhesion strength to be 0.1-0.7N when the cover tape is turned off from the carrier tape at 10°C angle to be the carrier tape.
- (4) Packaging : P/N, Manufacturing data Code No. and quantity to be indicated on a damp proof Package

# Reel Packing Structure

## 1) Reel

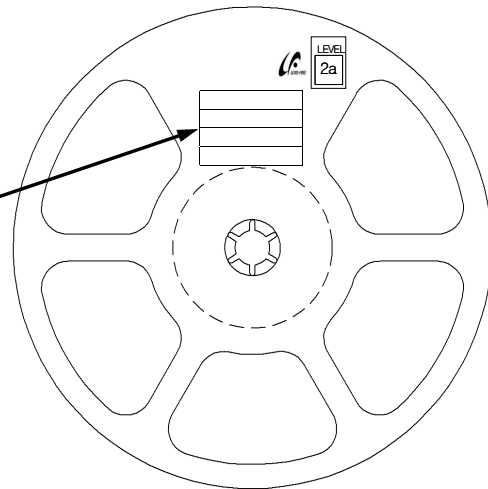
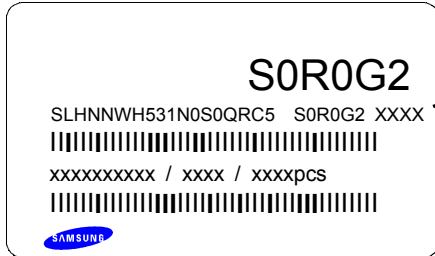

## 2) Aluminum Vinyl Bag

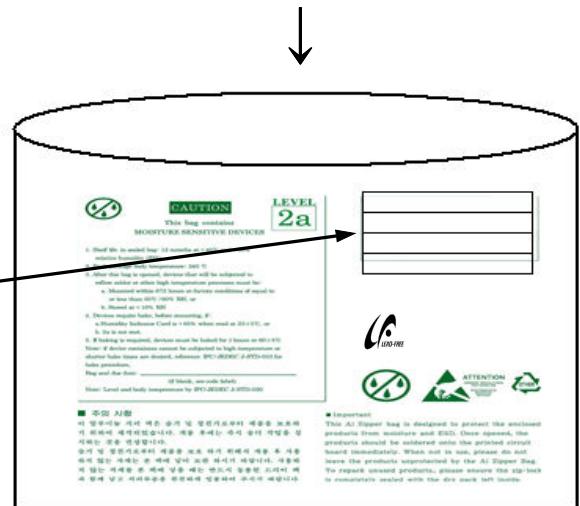
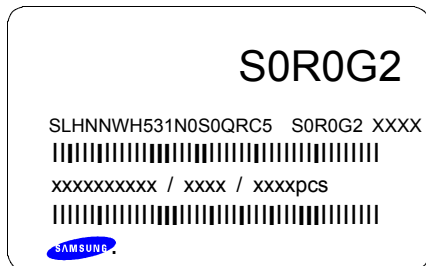

## 3) Inner Box

Material : Paper(SW3B(B))

TYPE	SIZE(mm)		
	(a)	(b)	(c)
13inch	335	45	335

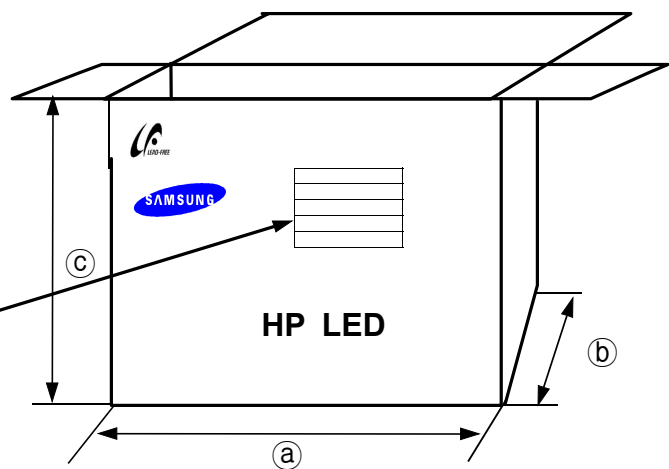

#### 4) Carton Box

Material : Paper(SW3B(B))

TYPE	SIZE(mm)		
	a	b	c
13inch	350	350	350

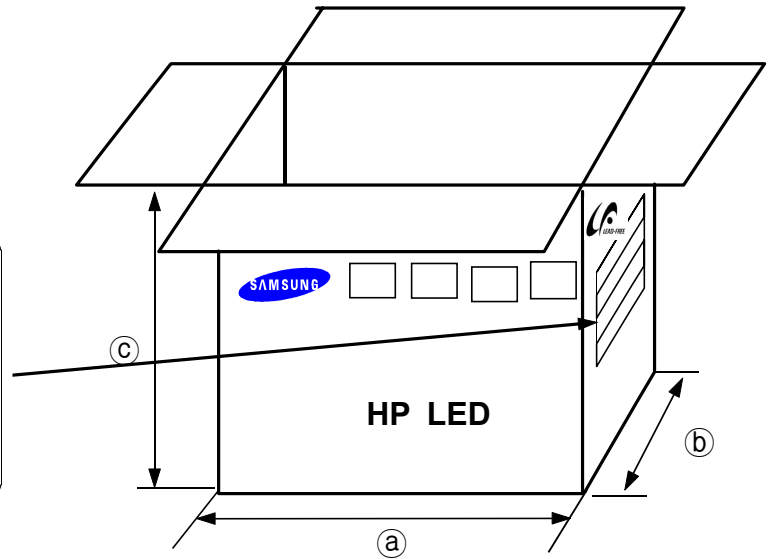
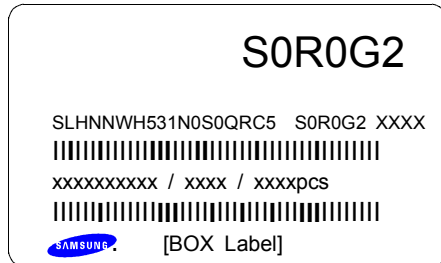

#### Label Structure

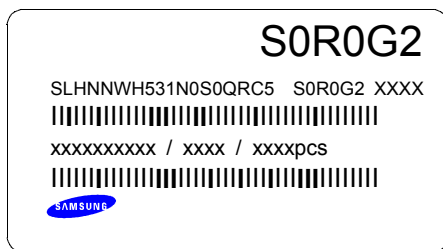

(S0): VF Rank  
(Q0): Chromaticity Coordinate Rank(CCT)  
(G2): Luminous Flux

#### Lot Number

The Lot number is composed of the following characters

●◎◇◆□■△△△ / |▲▲▲ / 2000PCS

- : Production Site (S:SEMCO, G:Gosin China)
- ◎ : L (LED)
- ◇ : Product State (A:Normality, B: Bulk, C:First Production, R:reproduction, S:Sample)
- ◆ : Year (Q:2006, R:2007, S:2008...)
- : Month (1 ~ 9, A, B)
- : Day (1 ~ 9, A, B ~ V)
- △ : SEMCo. Product number (1 ~ 999)
- ▲ : Reel Number (1 ~ 999)



**CAUTION**

This bag contains  
MOISTURE SENSITIVE DEVICES

**LEVEL**  
**2a**

1. Shelf life in sealed bag: 12 months at <math>40^{\circ}\text{C}</math> and <math>< 90\%</math> relative humidity (RH)
2. Peak package body temperature: <math>240^{\circ}\text{C}</math>
3. After this bag is opened, devices that will be subjected to reflow solder or other high temperature processes must be:
  - a. Mounted within 672 hours at factory conditions of equal to or less than <math>30^{\circ}\text{C}</math> / <math>60\%</math> RH, or
  - b. Stored at <math>< 10\%</math> RH
4. Devices require bake, before mounting, if:
  - a. Humidity Indicator Card is > <math>65\%</math> when read at <math>23 \pm 5^{\circ}\text{C}</math>, or
  - b. 2a is not met.
5. If baking is required, devices must be baked for 1 hours at <math>60 \pm 5^{\circ}\text{C}</math>

Note: if device containers cannot be subjected to high temperature or shorter bake times are desired, reference IPC/JEDEC J-STD-033 for bake procedure,

Bag seal due date: \_\_\_\_\_  
(if blank, see code label)

Note: Level and body temperature by IPC/JEDEC J-STD-020

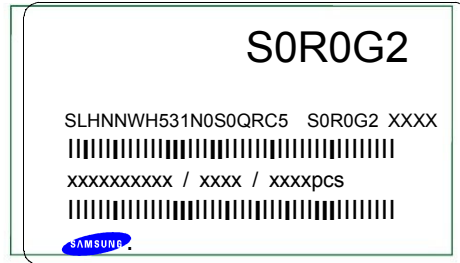

**ATTENTION**  
OBSERVE PRECAUTIONS  
FOR HANDLING  
ELECTROSTATIC  
SENSITIVE  
DEVICES



■ 주의 사항

이 알루미늄 지퍼 백은 습기 및 정전기로부터 제품을 보호하기 위하여 제작되었습니다. 개봉 후에는 즉시 솔더 작업을 실시하는 것을 권장합니다.

습기 및 정전기로부터 제품을 보호 하기 위해서 개봉 후 사용하지 않는 자재는 본 팩에 넣어 보관 하시기 바랍니다. 사용하지 않는 자재를 본 팩에 넣을 때는 반드시 동봉된 드라이 팩과 함께 넣고 지퍼부분을 완전하게 밀봉하여 주시기 바랍니다.

■ Important

This Al Zipper bag is designed to protect the enclosed products from moisture and ESD. Once opened, the products should be soldered onto the printed circuit board immediately. When not in use, please do not leave the products unprotected by the Al Zipper Bag. To repack unused products., please ensure the zip-lock is completely sealed with the dry pack left inside.

**Silical gel & Humidity Indicator Card in Aluminum Vinyl Bag**

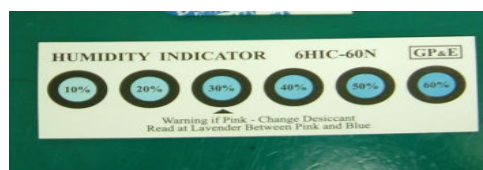

## ■ Precaution for Use

- 1) For over-current-proof function, customers are recommended to apply resistors to prevent sudden change of the current caused by slight shift of the voltage.
- 2) This device should not be used in any type of fluid such as water, oil, organic solvent, etc. When washing is required, IPA is recommended to use.
- 3) When the LEDs illuminate, operating current should be decided after considering the ambient maximum temperature.
- 4) LEDs must be stored in a clean environment.  
If the LEDs are to be stored for 3 months or more after being shipped from SEMCO, they should be packed by a sealed container with nitrogen gas injected. (Shelf life of sealed bags : 12 months, temp. 0~40°C, 20~70%RH)
- 5) After storage bag is open, device subjected to soldering, solder reflow, or other high temperature processes must be:
  - a. Mounted within 168 hours (7 days) at an assembly line with a condition of no more than 30°C/60%RH,
  - b. Stored at <10% RH.
- 6) Repack unused Products with anti-moisture packing, fold to close any opening and then store in a dry place.
- 7) Devices require baking before mounting, if humidity card reading is >60% at 23±5°C.
- 8) Devices must be baked for 24hours at 65±5°C, if baking is required.
- 9) The LEDs are sensitive to the static electricity and surge. It is recommended to use a wrist band or anti-electrostatic glove when handling the LEDs.

If voltage exceeding the absolute maximum rating is applied to LEDs, it may cause damage or even destruction to LED devices.

Damaged LEDs may show some unusual characteristics such as increase in leak current, lowered turn-on voltage, or abnormal lighting of LEDs at low current.

# Hazard Substance Analysis



**Test Report No.** F690501/LF-CTSAYA08-04155

Issued Date: February 11, 2008 Page 1 of 3

To: **SAMSUNG ELECTRO-MECHANICS CO., LTD.**  
314, Maetan3-dong  
Yeongtong-gu  
Suwon-city  
GYEONGGI-DO 442-373  
Korea

The following merchandise was submitted and identified by the client as :

**Product Name** : LED  
**SGS File No.** : AYA08-04155  
**Received Date** : February 04, 2008  
**Test Performing Date** : February 05, 2008  
**Test Performed** : SGS Testing Korea tested the sample(s) selected by applicant with following results  
**Test Results** : For further details, please refer to following page(s)  
**Comments** : The sampling and testing was performed only for the part indicated in the photo without disassembly by the applicant's specific request.

Pluto Kim  
Monet Jeong  
Billy Oh / Testing Person

SGS Testing Korea Co. Ltd.

Jeff Jang / Chemical Lab Mgr

This document is issued by the Company under its General Conditions of Service printed overleaf or available on request and accessible at [http://www.sgs.com/terms\\_and\\_conditions.htm](http://www.sgs.com/terms_and_conditions.htm). Attention is drawn to the limitation of liability, indemnification and jurisdiction issues defined therein. Any holder of this document is advised that information contained hereon reflects the Company's findings at the time of its intervention only and within the limits of Client's instructions, if any. The Company's sole responsibility is to its Client and this document does not exonerate parties to a transaction from exercising all their rights and obligations under the transaction documents. Any unauthorized alteration, forgery or falsification of the content or appearance of this document is unlawful and offenders may be prosecuted to the fullest extent of the law. Unless otherwise stated the results shown in this test report refer only to the sample(s) tested. This document cannot be reproduced except in full, without prior approval of the Company.

F052 Version2



**Test Report No. F690501/LF-CTSAYA08-04155**

Issued Date: February 11, 2008 Page 2 of 3

Sample No. : AYA08-04155.001  
 Sample Description : LED  
 Item No./Part No. : 7070 No Lens (Cool White)

**Heavy Metals**

Test Items	Unit	Test Method	MDL	Results
Cadmium (Cd)	mg/kg	US EPA 3050B(1996), US EPA 6010B(1996), ICP	0.5	N.D.
Lead (Pb)	mg/kg	US EPA 3050B(1996), US EPA 6010B(1996), ICP	5	N.D.
Mercury (Hg)	mg/kg	US EPA 3052(1996), US EPA 6010B(1996), ICP	2	N.D.
Hexavalent Chromium (Cr VI)	mg/kg	US EPA 3060A(1996), US EPA 7196A(1992), UV	1	N.D.

**Flame Retardants-PBBs/PBDEs**

Test Items	Unit	Test Method	MDL	Results
Monobromobiphenyl	mg/kg	US EPA 3540C, GC/MS	5	N.D.
Dibromobiphenyl	mg/kg	US EPA 3540C, GC/MS	5	N.D.
Tribromobiphenyl	mg/kg	US EPA 3540C, GC/MS	5	N.D.
Tetrabromobiphenyl	mg/kg	US EPA 3540C, GC/MS	5	N.D.
Pentabromobiphenyl	mg/kg	US EPA 3540C, GC/MS	5	N.D.
Hexabromobiphenyl	mg/kg	US EPA 3540C, GC/MS	5	N.D.
Heptabromobiphenyl	mg/kg	US EPA 3540C, GC/MS	5	N.D.
Octabromobiphenyl	mg/kg	US EPA 3540C, GC/MS	5	N.D.
Nonabromobiphenyl	mg/kg	US EPA 3540C, GC/MS	5	N.D.
Decabromobiphenyl	mg/kg	US EPA 3540C, GC/MS	5	N.D.
Monobromodiphenyl ether	mg/kg	US EPA 3540C, GC/MS	5	N.D.
Dibromodiphenyl ether	mg/kg	US EPA 3540C, GC/MS	5	N.D.
Tribromodiphenyl ether	mg/kg	US EPA 3540C, GC/MS	5	N.D.
Tetrabromodiphenyl ether	mg/kg	US EPA 3540C, GC/MS	5	N.D.
Pentabromodiphenyl ether	mg/kg	US EPA 3540C, GC/MS	5	N.D.
Hexabromodiphenyl ether	mg/kg	US EPA 3540C, GC/MS	5	N.D.
Heptabromodiphenyl ether	mg/kg	US EPA 3540C, GC/MS	5	N.D.
Octabromodiphenyl ether	mg/kg	US EPA 3540C, GC/MS	5	N.D.
Nonabromodiphenyl ether	mg/kg	US EPA 3540C, GC/MS	5	N.D.
Decabromodiphenyl ether	mg/kg	US EPA 3540C, GC/MS	5	N.D.

- NOTE: (1) N.D. = Not detected.(<MDL)  
 (2) mg/kg = ppm  
 (3) MDL = Method Detection Limit  
 (4) - = No regulation  
 (5) \*\* = Qualitative analysis (No Unit)  
 (6) Negative = Undetectable / Positive = Detectable

This document is issued by the Company under its General Conditions of Service printed overleaf or available on request and accessible at [http://www.sgs.com/terms\\_and\\_conditions.htm](http://www.sgs.com/terms_and_conditions.htm). Attention is drawn to the limitation of liability, indemnification and jurisdiction issues defined therein. Any holder of this document is advised that information contained hereon reflects the Company's findings at the time of its intervention only and within the limits of Client's instructions, if any. The Company's sole responsibility is to its Client and this document does not exonerate parties to a transaction from exercising all their rights and obligations under the transaction documents. Any unauthorized alteration, forgery or falsification of the content or appearance of this document is unlawful and offenders may be prosecuted to the fullest extent of the law. Unless otherwise stated the results shown in this test report refer only to the sample(s) tested. This document cannot be reproduced except in full, without prior approval of the Company.





Test Report No. F690501/LF-CTSAYA08-04155

Issued Date: February 11, 2008

Page 3 of 3



\*\*\* End \*\*\*

- NOTE:
- (1) N.D. = Not detected.(<MDL)
  - (2) mg/kg = ppm
  - (3) MDL = Method Detection Limit
  - (4) - = No regulation
  - (5) \*\* = Qualitative analysis (No Unit)
  - (6) Negative = Undetectable / Positive = Detectable

This document is issued by the Company under its General Conditions of Service printed overleaf or available on request and accessible at [http://www.sgs.com/terms\\_and\\_conditions.htm](http://www.sgs.com/terms_and_conditions.htm). Attention is drawn to the limitation of liability, indemnification and jurisdiction issues defined therein. Any holder of this document is advised that information contained hereon reflects the Company's findings at the time of its intervention only and within the limits of Client's instructions, if any. The Company's sole responsibility is to its Client and this document does not exonerate parties to a transaction from exercising all their rights and obligations under the transaction documents. Any unauthorized alteration, forgery or falsification of the content or appearance of this document is unlawful and offenders may be prosecuted to the fullest extent of the law. Unless otherwise stated the results shown in this test report refer only to the sample(s) tested. This document cannot be reproduced except in full, without prior approval of the Company.

F052 Version2

