

materiały pobrane ze strony:

<https://www.instructables.com/id/Digispark-DIY-The-smallest-USB-Arduino/>
2017-06-21

Digispark DIY: the Smallest USB Arduino

by [smching](#) in [arduino](#)

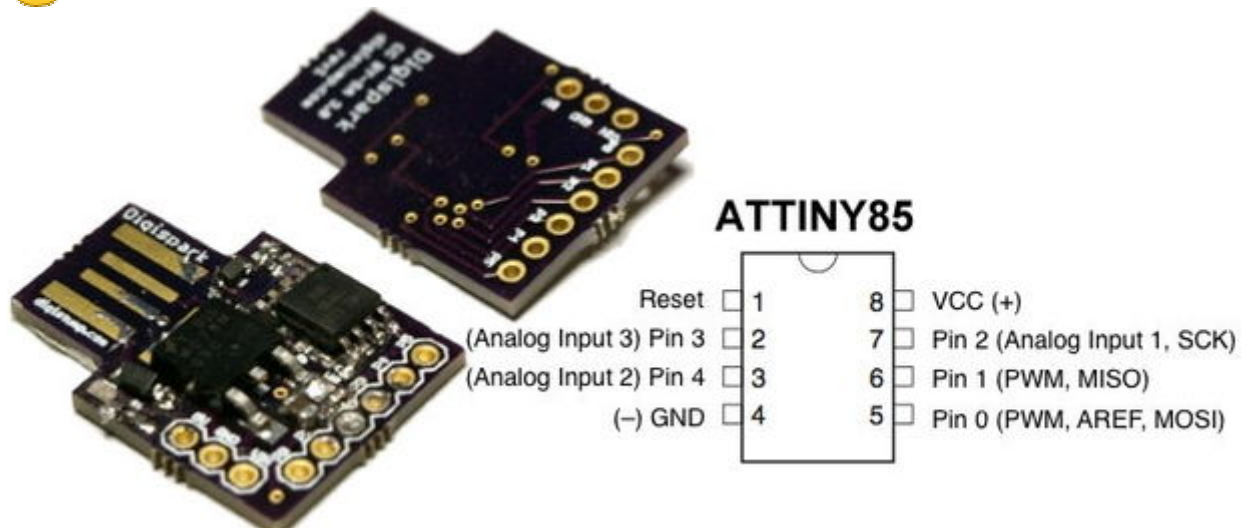

[Digispark](#) is an ATtiny85 based microcontroller development board come with USB interface. Coding is similar to Arduino, and it use the familiar Arduino IDE for development.

[Digispark](#) is copyrighted by Digistump LLC (digistump.com) and the full license is here: <http://digistump.com/wiki/digispark/policy>

Specification:

Support for the Arduino IDE 1.0+ (OSX/Win/Linux)

Power via USB or External Source - 5v or 7-35v (automatic selection)

On-board 500ma 5V Regulator

Built-in USB (and serial debugging)

6 I/O Pins (2 are used for USB only if your program actively communicates over USB, otherwise you can use all 6 even if you are programming via USB)

8k Flash Memory (about 6k after bootloader)

I2C and SPI (vis USI)

PWM on 3 pins (more possible with Software PWM)

ADC on 4 pins

Power LED and Test/Status LED (on Pin0)

Step 1: Prerequisite



USB Cable



AVRISP MKII

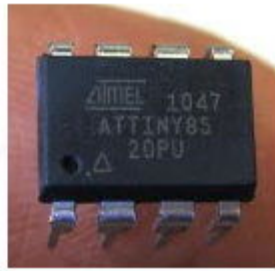

ATTINY85

AVRISP MKII In-System Programmer

ATTINY85 Microcontroller

2 x 3.6V zener diode

2 x 68 ohm resistor

1 x 1.5K resistor

USB cable (get from broken mouse or keyboard)

Some wires

Step 2: Burning Bootloader to ATTINY85

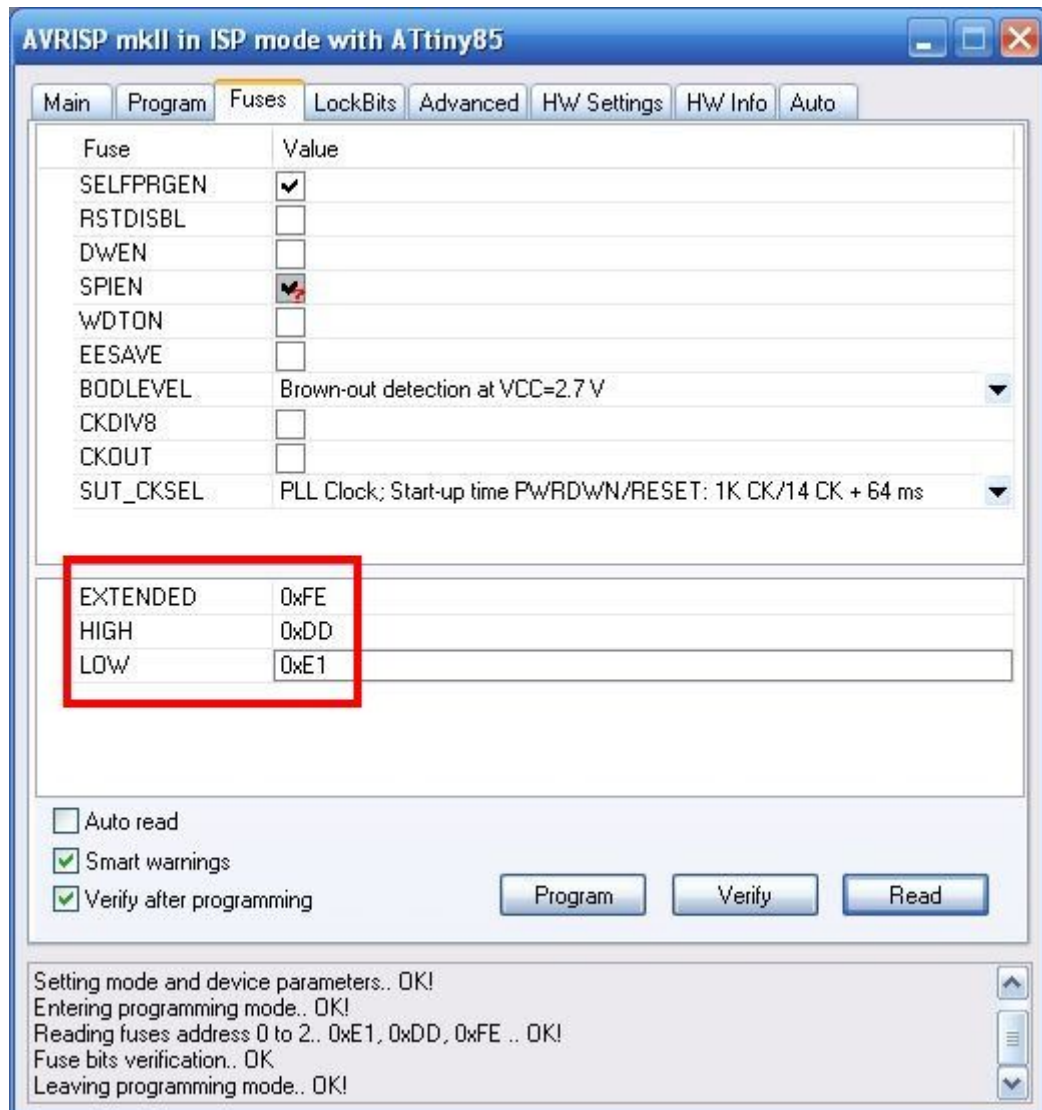

ATTIN85

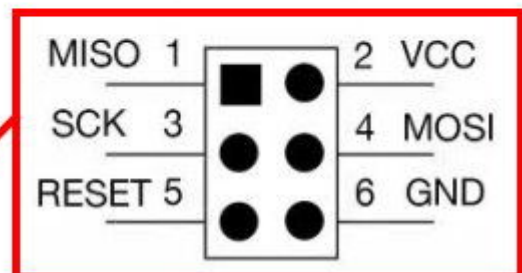
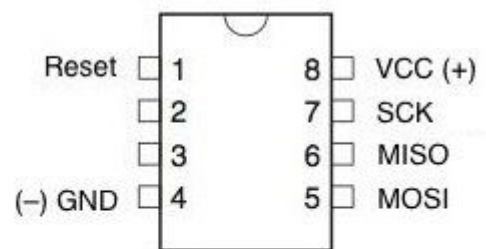

Like Arduino, Digispark require a bootloader to be running on ATTINY85. The bootloader will occupied 2KB flash memory.

Download bootloader

1. [Download Micronucleus bootloader](#) for ATTINY85
2. Extract the file (micronucleus-t85-master.zip) to any folder
3. You can find the bootloader file at micronucleus-t85-master\firmware\releases folder
4. Use micronucleus-1.06.hex for the bootloader

Burning bootloader to ATTINY85

You must use the correct fuses bit for the bootloader

Extended: 0xFE

High: 0xDD

Low: 0xE1

Note: The above fuse bit will not enable reset as I/O, so you can have only 5 I/O instead of 6 I/O. I'm still try to figure out on how to set it to 6 I/O

I'm using AVRISP MKII In System Programmer and AVR Studio software for burning bootloader.

Step 3: Installing Digispark USB Driver

Digispark use USB to communicate with computer, so your computer must install Digispark USB driver

1. [Download Arduino for Digispark](#) which come with USB driver
2. Extract the file (DigisparkArduino-Win32-1.0.4-March29.zip) to any folder
3. Execute DigisparkArduino-Win32\DigisparkWindowsDriver\InstallDriver.exe to start installing the USB driver

Step 4: Digispark Schematic

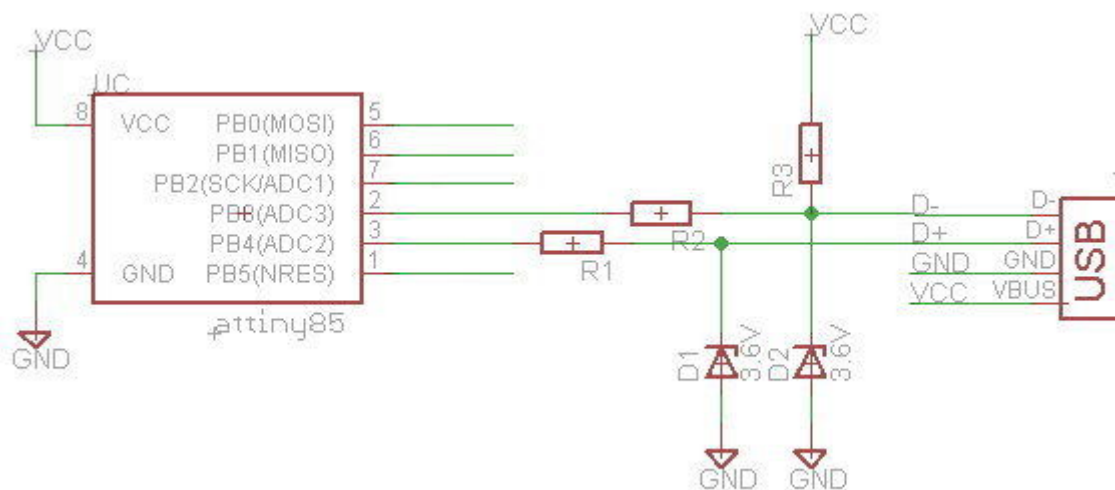
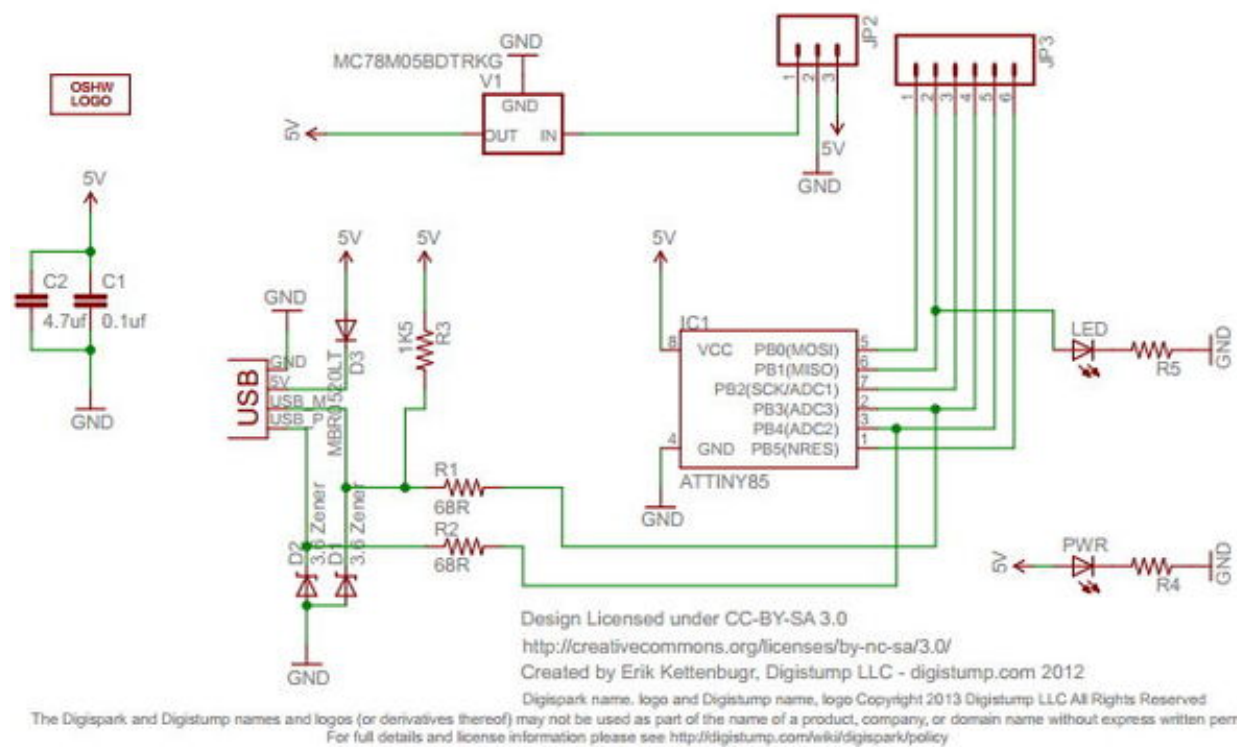

I provide two schematics, first one is the official schematic for Digispark, the other one is for testing purposes which the 5v is get from USB port and hence it is lesser components and much more simple.

Step 5: Plug in Digispark to Computer



1. Plug in Digispark to the USB port of computer
2. USB device is detected for first time use and prompt you to installing Digispark bootloader.
3. Click on Next button until finish.

Step 6: Configure Digispark Software

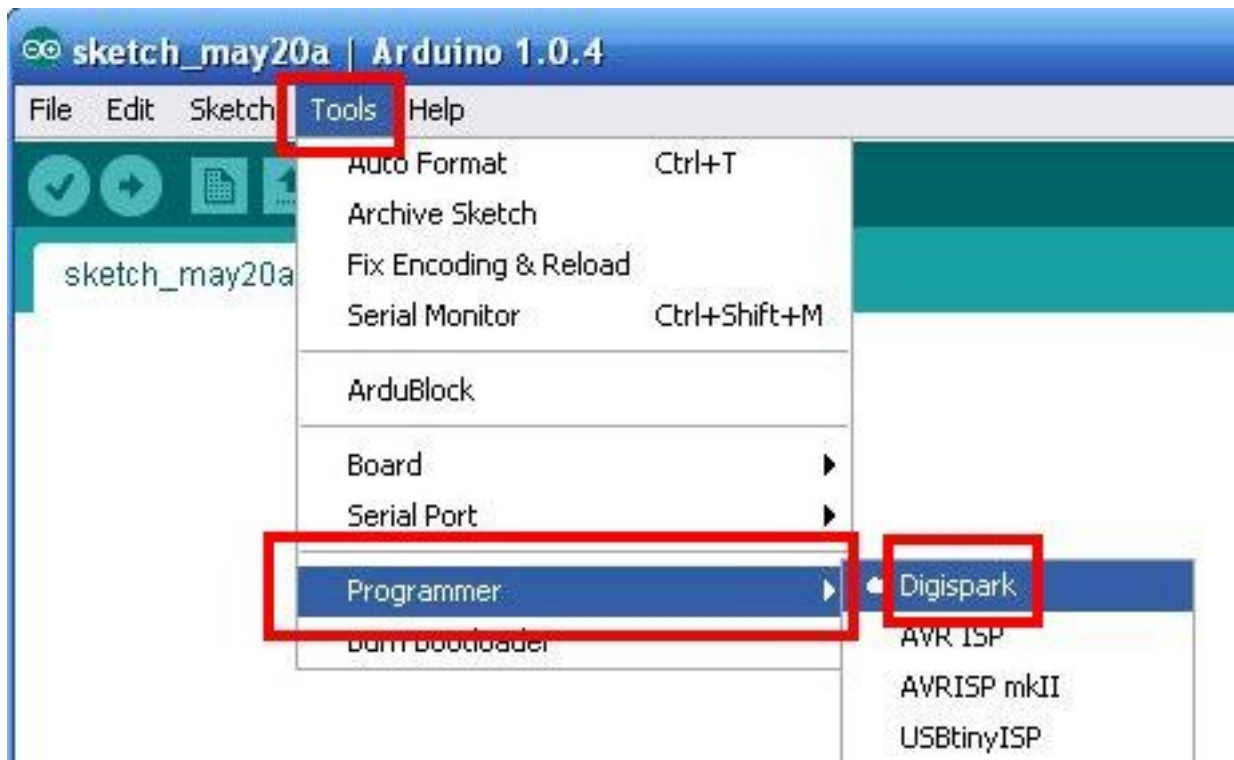

1. Run DigisparkArduino-Win32\Digispark-Arduino-1.0.4\arduino.exe to starting Arduino IDE
2. Click on Tools>Board>Digispark (Tiny Core)
3. Click on Tools>Programmer>Digispark

Step 7: Upload Sketch to Digispark

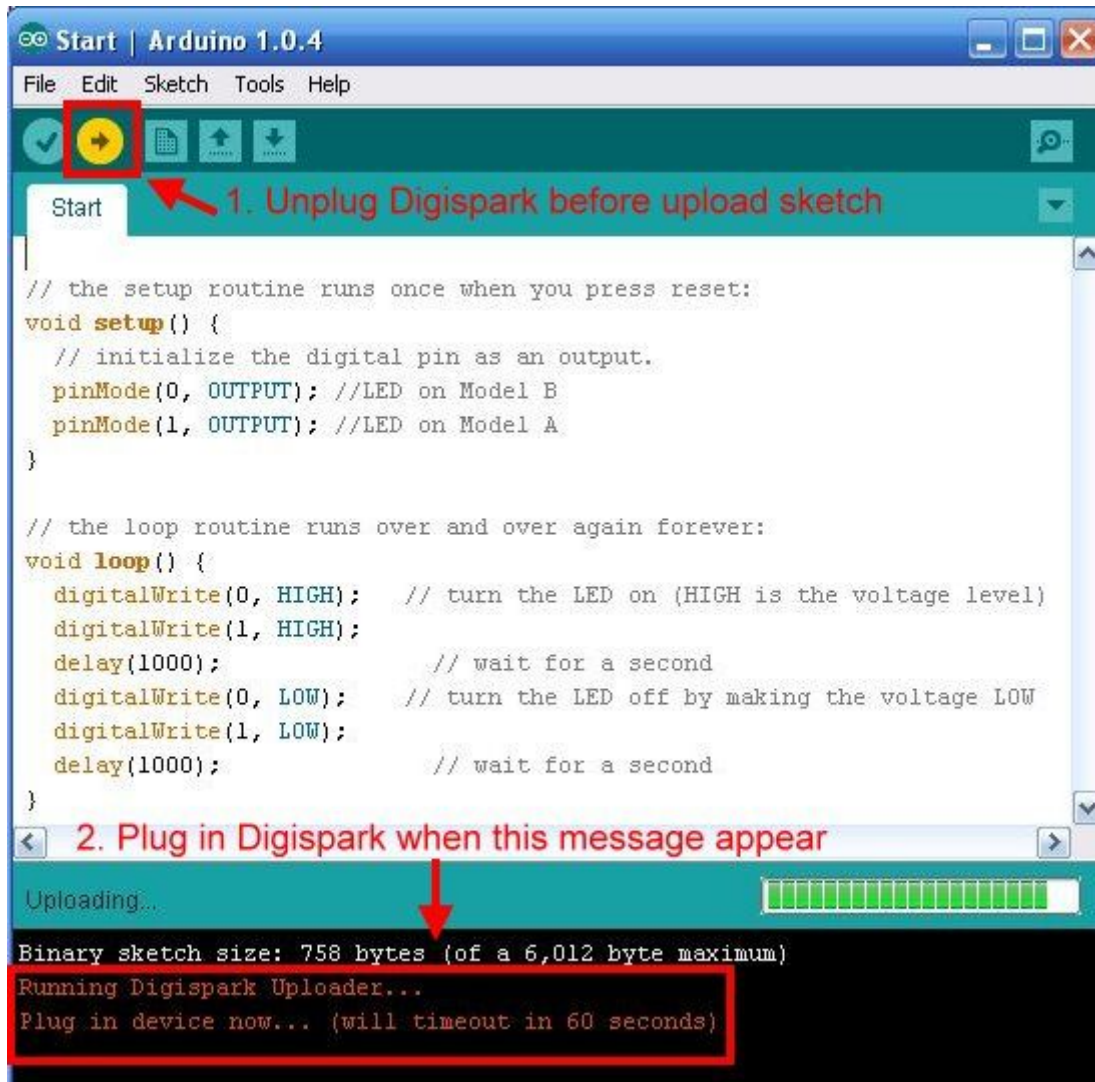

Start | Arduino 1.0.4

File Edit Sketch Tools Help

Start

1. Unplug Digispark before upload sketch

```
// the setup routine runs once when you press reset:
void setup() {
  // initialize the digital pin as an output.
  pinMode(0, OUTPUT); //LED on Model B
  pinMode(1, OUTPUT); //LED on Model A
}

// the loop routine runs over and over again forever:
void loop() {
  digitalWrite(0, HIGH); // turn the LED on (HIGH is the voltage level)
  digitalWrite(1, HIGH);
  delay(1000); // wait for a second
  digitalWrite(0, LOW); // turn the LED off by making the voltage LOW
  digitalWrite(1, LOW);
  delay(1000); // wait for a second
}
```

2. Plug in Digispark when this message appear

Uploading...

Binary sketch size: 758 bytes (of a 6,012 byte maximum)

Running Digispark Uploader...

Plug in device now... (will timeout in 60 seconds)

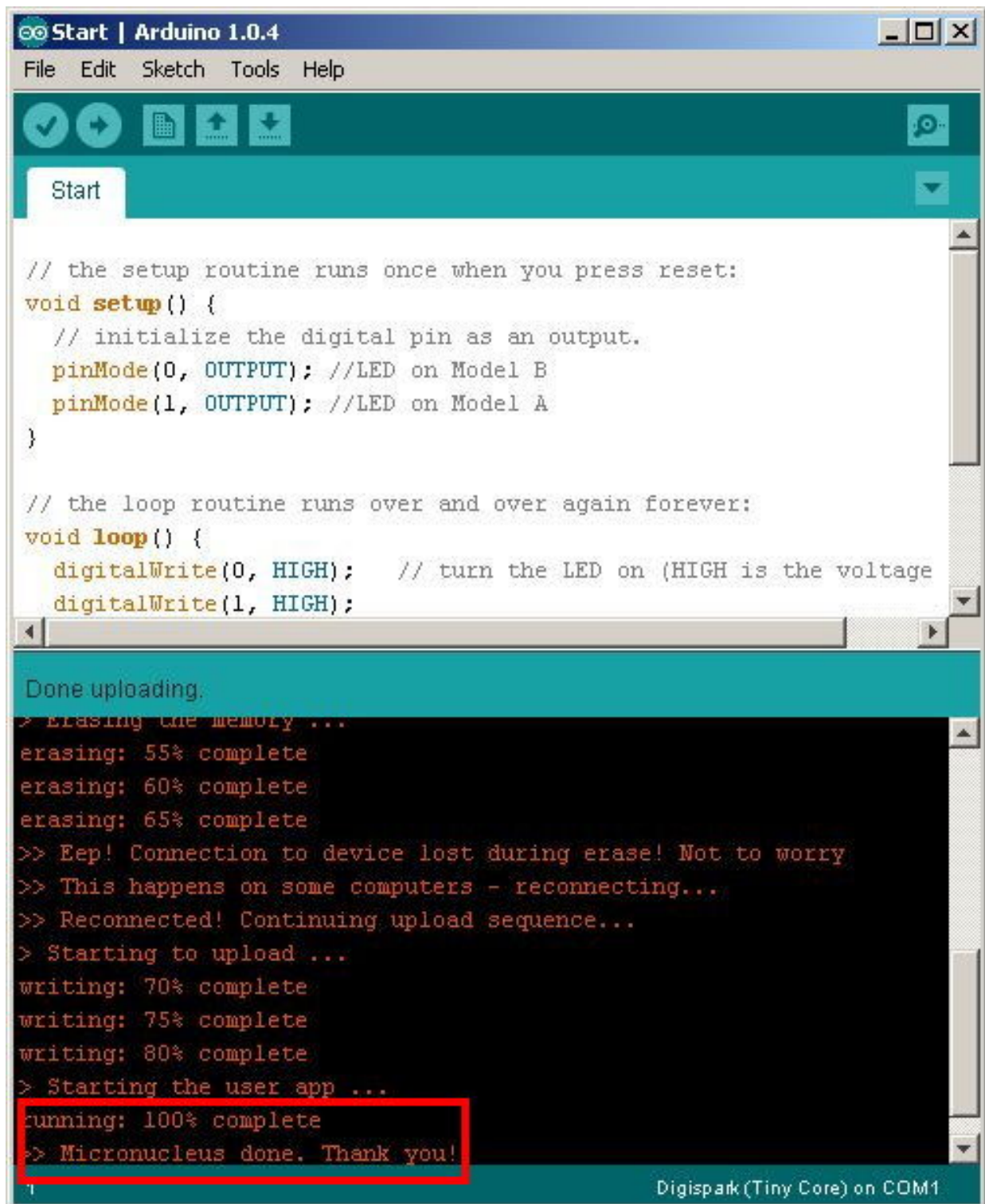

Upload an example. Click on File > Examples > Digispark_Example > Start
Coding is look like this:

```
// the setup routine runs once when you press reset:
void setup() {
  // initialize the digital pin as an output.
  pinMode(0, OUTPUT); //LED on Model B
  pinMode(1, OUTPUT); //LED on Model A
```

```
}  
// the loop routine runs over and over again forever:  
void loop() {  
  digitalWrite(0, HIGH); // turn the LED on (HIGH is the voltage level)  
  digitalWrite(1, HIGH);  
  delay(1000);           // wait for a second  
  digitalWrite(0, LOW);  // turn the LED off by making the voltage LOW  
  digitalWrite(1, LOW);  
  delay(1000);           // wait for a second  
}
```

Follow step below to upload sketch to Digispark.

1. Unplug Digispark from computer before click on the Upload button
2. Click on Upload button now
3. Plug in Digispark to computer when it prompt for "Plug in device now..."
4. If you see "**running: 100% complete**". Congraturation! you have own a working Digispark.

Step 8: Test the Digispark

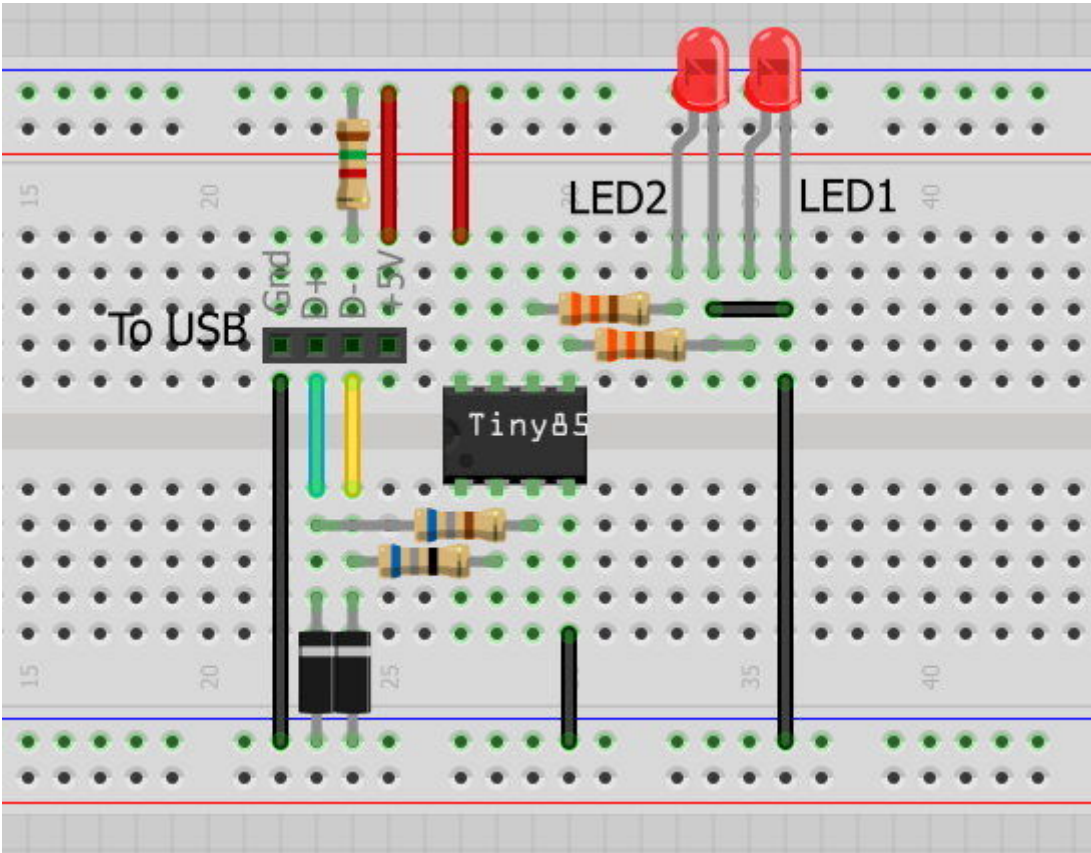

Connect a 330ohm resistor & LED to both pin5(Digital 0) and pin6(Digital 1) of ATTINY85. Plug the Digispark to computer, both LED is start blinking now.

Step 9: What Can Do With Digispark



See examples

My website:

<http://ediy.com.my/index.php/blog/item/72-digispark-diy-the-smallest-usb-arduino>