

Aluminum Capacitors + 105 °C, Snap-in

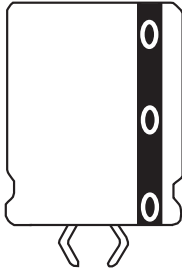

Fig.1 Component Outlines.

FEATURES

- Operating temperature to + 105 °C
- High ripple current capability
- Low ESR



QUICK REFERENCE DATA	
DESCRIPTION	VALUE
Nominal case size ØD x L in mm	0.87" x 1.00" [22.0 x 25.0] to 1.38" x 3.15" [35.0 x 80.0]
Operating temperature	- 40 °C to + 105 °C
Rated Capacitance	68 µF to 47 000 µF
Capacitance Tolerance	± 20 %
Voltage Rating	16 WVDC to 400 WVDC
Termination	Snap mount
Life validation test at 105 °C	2000 hours: Δ CAP ≤ 15 % from initial measurement. Δ ESR ≤ 1.3 x initial specified limit. Δ DCL ≤ initial specified limit
Shelf life at 85 °C	500 hours: Δ CAP ≤ 15 % from initial measurement. Δ ESR ≤ 1.3 x initial specified limit. Δ DCL ≤ 2 x initial specified limit
DC leakage current	$I = K\sqrt{CV}$ K = 4.0 at + 25 °C I in µA, C in µF, V in Volts

RIPPLE CURRENT MULTIPLIERS				
TEMPERATURE				
AMBIENT TEMPERATURE		MULTIPLIERS		
+ 55 °C		1.6		
+ 65 °C		1.4		
+ 75 °C		1.2		
+ 85 °C		1.0		
+ 95 °C		0.70		
+ 105 °C		0.50		
FREQUENCY (Hz)				
WVDC	50-60	300 - 1000	1000 AND UP	
0 - 49	0.85	1.10	1.15	
50 - 199	0.83	1.15	1.20	
200 - 250	0.80	1.30	1.40	
ESL (TYPICAL VALUES at 1 MHz to 10 MHz)				
Nominal Diameter	0.87 [22.0]	0.98 [25.0]	1.18 [30.0]	1.38 [35.0]
Typical ESL (nH)	6.0	8.0	10.0	12.0

DIMENSIONS in inches [millimeters]					
CASE CODE	DIAMETER		CASE CODE	LENGTH	
	D + 0.04 - 0 [+ 1.0 - 0]			L ± 0.08 [2.0]	
HA	0.87 [22.0]	1.00 [25.0]	KC	1.18 [30.0]	1.38 [35.0]
HB	0.87 [22.0]	1.18 [30.0]	KD	1.18 [30.0]	1.57 [40.0]
HD	0.87 [22.0]	1.57 [40.0]	KE	1.18 [30.0]	2.00 [50.0]
JA	1.00 [25.0]	1.00 [25.0]	MB	1.38 [35.0]	1.18 [30.0]
JB	1.00 [25.0]	1.18 [30.0]	MC	1.38 [35.0]	1.38 [35.0]
JC	1.00 [25.0]	1.38 [35.0]	MD	1.38 [35.0]	1.57 [40.0]
JD	1.00 [25.0]	1.57 [40.0]	ME	1.38 [35.0]	2.00 [50.0]
JE	1.00 [25.0]	2.00 [50.0]	MF	1.38 [35.0]	2.50 [63.0]
KA	1.18 [30.0]	1.00 [25.0]	MG	1.38 [35.0]	3.18 [80.0]
KB	1.18 [30.0]	1.18 [30.0]			

DIMENSIONS in inches [millimeters]					
CIRCUIT BOARD MOUNT TERMINAL DIMENSIONS*					
DIAMETER		STYLE A			STYLE B
D	CASE CODE	B	R	C	R
1.00 [25.0]	J	0.093 [2.4]	0.301 [7.6]	140 °	N/A
1.18 [30.0]	K	0.125 [3.2]	0.363 [9.2]	120 °	0.391 [9.9]
1.38 [35.0]	M	0.125 [3.2]	0.458 [11.6]	120 °	0.458 [11.6]

*Style A and B not available in 0.87" [22.0mm] diameter units.

DIMENSIONS AND AVAILABLE FORMS

Style A

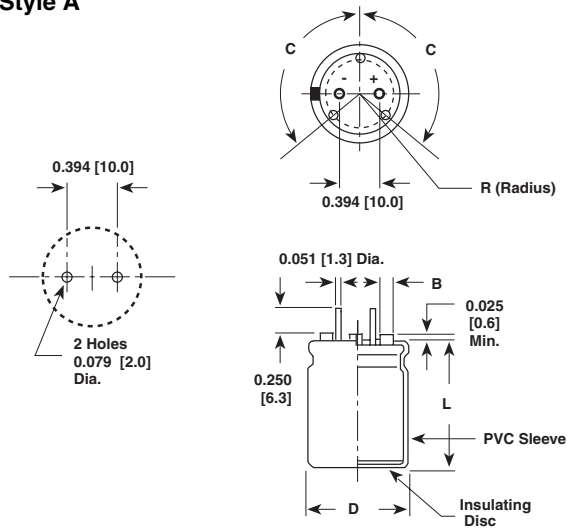

Style B

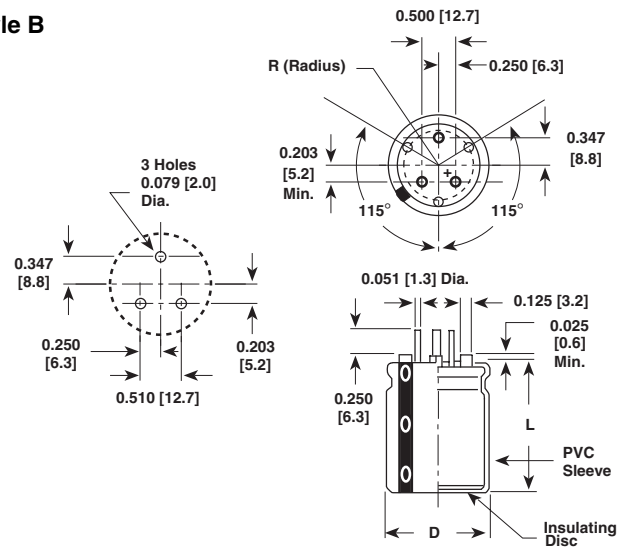

Style D

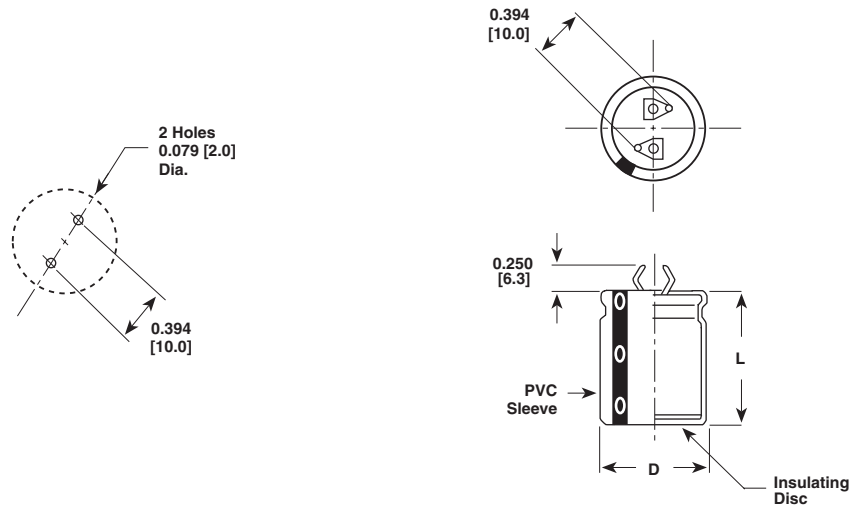

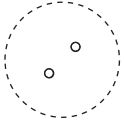
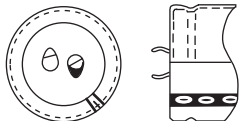
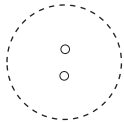
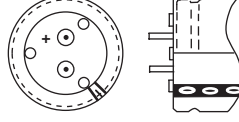
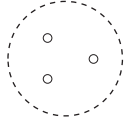
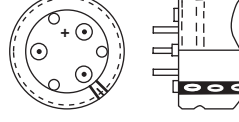
TERMINAL CONFIGURATION [numbers in brackets indicate millimeters]					
LEAD CODE	DESCRIPTION	OUTLINE DRAWINGS		AVAILABLE DIAMETERS	AVAILABLE VOLTAGES AND TYPES
		MOUNTING CONFIGURATION	TERMINAL CONFIGURATION		
D	Standard 2 pin snap in			0.87 [22.0] - H 0.98 [25.0] - J 1.18 [30.0] - K 1.38 [35.0] - M	All voltages 81D, 81DA 82D, 82DA
A	2 straight wire lead molded cover with standoffs			0.98 [25.0] - J 1.18 [30.0] - K 1.38 [35.0] - M	All voltages 82D, 82DA V < = 250 VDC 81D, 81DA
B	3 straight wire lead molded cover with standoffs			1.18 [30.0] - K 1.38 [35.0] - M	All voltages 82D, 82DA V < = 250 VDC 81D, 81DA

ELECTRICAL DATA	
SYMBOL	DESCRIPTION
μF	rated capacitance
± %	P = ± 20 %
DC	voltage rating at 105° C
HA	see dimensions in millimeters table
2	PVC insulating sleeve
D	2 pin snap-in

ORDERING EXAMPLE*

Electrolytic capacitor 81D series

81D 882 M 6R3 HA 2 D

*Note for lead (Pb)-free, add suffix E3 to part number.

Example: 81D882M6R3HA2DE3

ELECTRICAL DATA AND ORDERING INFORMATION						
CAPACITANCE (μF)	PART NUMBER	NOMINAL CASE SIZE D X L	MAX. ESR at 25 °C (mΩ)		MAX. RIPPLE at + 85 °C (A)	
			120 Hz	20 k - 40 kHz	120 Hz	20 k - 40 kHz
16 WVDC at + 105 °C, SURGE = 20 V						
15000.0	81D153M016JC2D	0.984 x 1.378 [25.0 x 35.0]	58.0	43.0	4.72	5.47
22000.0	81D223M016KB2D	1.181 x 1.181 [30.0 x 30.0]	53.7	41.0	5.24	5.94
33000.0	81D333M016MC2D	1.378 x 1.378 [35.0 x 35.0]	28.0	21.0	8.42	9.71
47000.0	81D473M016MD2D	1.378 x 1.575 [35.0 x 40.0]	23.0	17.0	9.70	11.20
25 WVDC at + 105 °C, SURGE = 30 V						
3300.0	81D332M025HA2D	0.866 x 0.984 [22.0 x 25.0]	110.0	76.0	2.81	3.38
4700.0	81D472M025JA2D	0.984 x 0.984 [25.0 x 25.0]	86.0	60.0	3.44	4.15
6800.0	81D682M025KA2D	1.181 x 0.984 [30.0 x 25.0]	71.0	54.0	4.25	4.91
10000.0	81D103M025KB2D	1.181 x 1.181 [30.0 x 30.0]	54.0	41.0	5.24	5.94
15000.0	81D153M025KD2D	1.181 x 1.575 [30.0 x 40.0]	36.4	27.0	7.07	8.16
22000.0*	81D223M025MD2D	1.378 x 1.575 [35.0 x 40.0]	23.0	17.0	9.41	11.20

*These ratings are normally stocked.



Aluminum Capacitors
+ 105 °C, Snap-in

Vishay Sprague

ELECTRICAL DATA AND ORDERING INFORMATION						
CAPACITANCE (μ F)	PART NUMBER	NOMINAL CASE SIZE D X L	MAX. ESR at 25 °C (m Ω)		MAX. RIPPLE at + 85 °C (A)	
			120 Hz	20 k - 40 kHz	120 Hz	20 k - 40 kHz
35 WVDC at + 105 °C, SURGE = 40 V						
4700.0	81D472M035KA2D	1.181 x 0.984 [30.0 x 25.0]	75.0	54.0	4.13	4.84
6800.0	81D682M035KB2D	1.181 x 1.181 [30.0 x 30.0]	57.0	41.0	5.10	5.94
12000.0	81D123M035KD2D	1.181 x 1.575 [30.0 x 40.0]	37.7	27.0	6.92	8.16
10000.0	81D103M035MB2D	1.378 x 1.181 [35.0 x 30.0]	36.0	24.0	7.04	8.63
50 WVDC at + 105 °C, SURGE = 63 V						
1200.0	81D122M050HA2D	0.866 x 0.984 [22.0 x 25.0]	148.0	79.0	2.41	3.29
2200.0	81D222M050JB2D	0.984 x 1.181 [25.0 x 30.0]	85.0	48.0	3.69	4.93
4700.0	81D472M050KC2D	1.181 x 1.378 [30.0 x 35.0]	53.0	33.0	5.51	7.05
6800.0*	81D682M050KE2D	1.181 x 1.969 [30.0 x 50.0]	33.0	22.0	8.04	9.74
63 WVDC at + 105 °C, SURGE = 79 V						
1000.0	81D102M063HA2D	0.866 x 0.984 [22.0 x 25.0]	151.0	75.0	2.39	3.39
1500.0	81D152M063HB2D	0.866 x 1.181 [22.0 x 30.0]	118.0	59.0	2.87	4.06
2200.0	81D222M063JC2D	0.984 x 1.378 [25.0 x 35.0]	72.0	38.0	4.21	5.78
4700.0	81D472M063KD2D	1.181 x 1.575 [30.0 x 40.0]	44.0	27.0	6.32	8.16
100 WVDC at + 105 °C, SURGE = 125 V						
470.0	81D471M100HB2D	0.866 x 1.181 [22.0 x 30.0]	258.0	114.0	1.94	2.93
680.0	81D681M100JB2D	0.984 x 1.181 [25.0 x 30.0]	188.0	86.0	2.48	3.67
1000.0	81D102M100KB2D	1.181 x 1.181 [30.0 x 30.0]	136.0	66.0	3.28	4.69
1500.0	81D152M100KC2D	1.181 x 1.378 [30.0 x 35.0]	106.0	52.0	3.90	5.59
2200.0*	81D222M100KE2D	1.181 x 1.969 [30.0 x 50.0]	66.0	33.0	5.69	8.05
200 WVDC at + 105 °C, SURGE = 250V						
220.0	81D221M200JA2D	0.984 x 0.984 [25.0 x 25.0]	625.0	272.0	1.37	2.08
330.0	81D331M200KA2D	1.181 x 0.984 [30.0 x 25.0]	498.0	192.0	1.71	2.77
470.0	81D471M200KB2D	1.181 x 1.181 [30.0 x 30.0]	294.0	136.0	2.39	3.51
1000.0	81D102M200KE2D	1.181 x 1.969 [30.0 x 50.0]	142.0	67.0	4.09	5.95
820.0	81D821M200MC2D	1.378 x 1.378 [35.0 x 35.0]	189.0	93.0	3.47	4.94
1000.0*	81D102M200MD2D	1.378 x 1.575 [35.0 x 40.0]	149.0	74.0	4.07	5.78
250 WVDC at + 105 °C, SURGE = 300V						
220.0	81D221M250HD2D	0.866 x 1.575 [22.0 x 40.0]	558.0	166.0	1.57	2.89
330.0	81D331M250JD2D	0.984 x 1.575 [25.0 x 40.0]	382.0	121.0	2.12	3.81
470.0	81D471M250JE2D	0.984 x 1.969 [25.0 x 25.0]	243.0	93.0	2.81	4.54
680.0	81D681M250KE2D	1.181 x 1.969 [30.0 x 50.0]	198.0	67.0	3.47	5.99
1000.0*	81D102M250ME2D	1.378 x 1.969 [35.0 x 50.0]	132.0	58.0	4.69	7.07
400 WVDC at + 105 °C, SURGE = 450V						
68.0	81D680M400HB2D	0.866 x 1.181 [22.0 x 30.0]	3550.0	1890.0	0.536	0.707
100.0	81D101M400JB2D	0.984 x 1.181 [25.0 x 30.0]	2920.0	1550.0	0.683	0.902
150.0	81D151M400JD2D	0.984 x 1.575 [25.0 x 40.0]	1650.0	880.0	1.000	1.1329
220.0	81D221M400KD2D	1.181 x 1.575 [30.0 x 40.0]	1110.0	580.0	1.476	1.781
330.0	81D331M400MD2D	1.378 x 1.575 [35.0 x 40.0]	730.0	390.0	1.695	2.257

*These ratings are normally stocked.



Disclaimer

All product specifications and data are subject to change without notice.

Vishay Intertechnology, Inc., its affiliates, agents, and employees, and all persons acting on its or their behalf (collectively, "Vishay"), disclaim any and all liability for any errors, inaccuracies or incompleteness contained herein or in any other disclosure relating to any product.

Vishay disclaims any and all liability arising out of the use or application of any product described herein or of any information provided herein to the maximum extent permitted by law. The product specifications do not expand or otherwise modify Vishay's terms and conditions of purchase, including but not limited to the warranty expressed therein, which apply to these products.

No license, express or implied, by estoppel or otherwise, to any intellectual property rights is granted by this document or by any conduct of Vishay.

The products shown herein are not designed for use in medical, life-saving, or life-sustaining applications unless otherwise expressly indicated. Customers using or selling Vishay products not expressly indicated for use in such applications do so entirely at their own risk and agree to fully indemnify Vishay for any damages arising or resulting from such use or sale. Please contact authorized Vishay personnel to obtain written terms and conditions regarding products designed for such applications.

Product names and markings noted herein may be trademarks of their respective owners.