

2N4427

**RF & MICROWAVE DISCRETE
LOW POWER TRANSISTORS**

Features

- Silicon NPN, To-39 packaged VHF/UHF Transistor
- 1 Watt Minimum Power Output @ 175 MHz
- 500 MHz Current-Gain Bandwidth Product @ 50mA
- Power Gain, $G_{PE} = 10\text{dB (Min)}$ @ 175 MHz

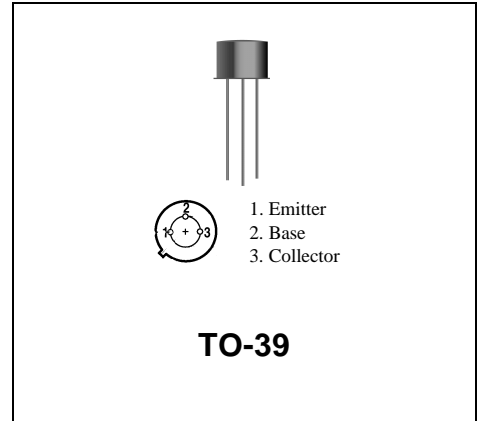

DESCRIPTION:

Silicon NPN transistor, designed for VHF and UHF equipment. Applications include amplifier; pre-driver, driver, and output stages. Also suitable for oscillator and frequency-multiplier functions.

ABSOLUTE MAXIMUM RATINGS (T_{case} = 25°C)

Symbol	Parameter	Value	Unit
V _{CEO}	Collector-Emitter	20	Vdc
V _{CBO}	Collector-Base Voltage	40	Vdc
V _{EBO}	Emitter-Base Voltage	2.0	Vdc
I _C	Collector Current	400	mA

Thermal Data

P _D	Total Device Dissipation @ T _A = 25°C Derate above 25°C	1.0 5.71	Watts mW/°C
----------------	---	-------------	----------------

ELECTRICAL SPECIFICATIONS (T_{case} = 25°C)
STATIC

(off)

Symbol	Test Conditions	Value			Unit
		Min.	Typ.	Max.	
BVCER	Collector-Emitter Sustaining Voltage (I _C = 5.0 mA _{dc} , R _{BE} = 10 ohms)	40	-	-	V _{dc}
BVCEO	Collector-Emitter Sustaining Voltage (I _C = 5.0 mA _{dc} , I _B = 0)	20	-	-	V _{dc}
ICEO	Collector Cutoff Current (V _{CE} = 12 V _{dc} , I _B = 0)	-	-	20	μA
ICEX	Collector Cutoff Current (V _{CE} = 40 V _{dc} , V _{BE} = -1.5 V _{dc})	-	-	100	μA
IEBO	Emitter Cutoff Current (V _{EB} = 2.0 V _{dc} , I _C = 0)	-	-	100	μA

(on)

HFE	DC Current Gain (I _C = 100 mA _{dc} , V _{CE} = 5.0 V _{dc}) (I _C = 360 mA _{dc} , V _{CE} = 5.0 V _{dc})	10	-	200	-
		5	-	-	-
VCE(sat)	Collector-Emitter Saturation Voltage (I _C = 100 mA _{dc} , I _B = 20 mA _{dc})	-	-	0.5	V _{dc}

DYNAMIC

Symbol	Test Conditions	Value			Unit
		Min.	Typ.	Max.	
f _T	Current-Gain - Bandwidth Product (I _C = 50 mA _{dc} , V _{CE} = 15 V _{dc} , f = 200 MHz)	500	-	-	MHz
COB	Output Capacitance (V _{CB} = 12 V _{dc} , I _E = 0, f = 1.0 MHz)	-	4.0	-	pF

2N4427

ELECTRICAL SPECIFICATIONS (T_{case} = 25°C)

FUNCTIONAL

Symbol	Test Conditions		Value			Unit
			Min.	Typ.	Max.	
G _{PE}	Power Gain	Test Circuit-Figure 1 Pin = 0.1 W, VCE = 12Vdc f = 175 MHz	10	-	-	dB
P _{out}	Output Power	Test Circuit-Figure 1 Pin = 0.1 W, VCE = 12Vdc f = 175 MHz	1.0	-	-	Watts
η _c	Collector Efficiency	Test Circuit-Figure 1 Pin = 0.1 W, VCE = 12Vdc f = 175 MHz	45	-	-	%

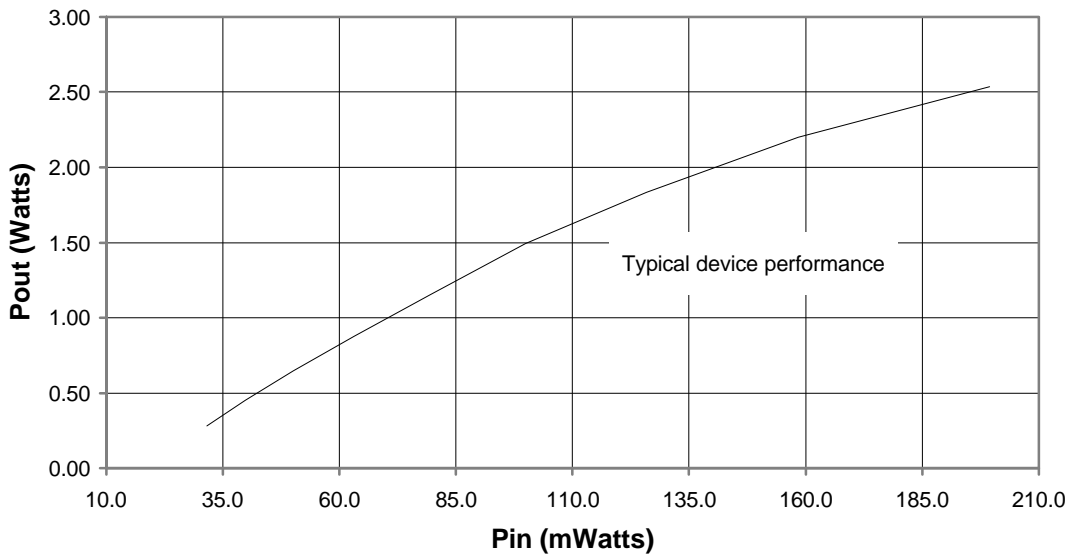

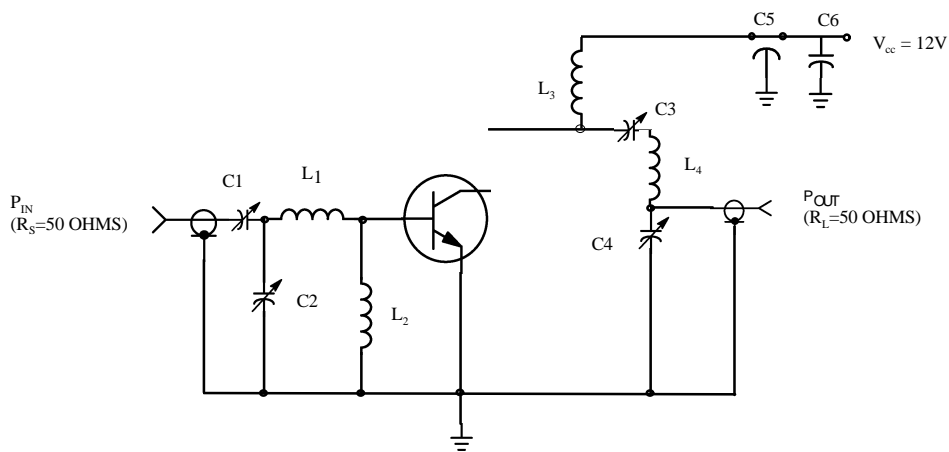

Figure 1 - 175 MHz RF AMPLIFIER CIRCUIT FOR G_{PE} , P_{OUT} , AND EFFICIENCY SPECIFICATIONS.

L₁: 2 TURNS No. 16 wire, 3/16" ID, 1/4" long

L₃: 2 TURNS No. 16 wire, 1/4" ID, 1/4" long

Capacitor values in pF unless

L₂: Ferrite choke, Z=450 ohms

L₄: 4 TURNS No. 16 wire, 3/8" ID, 3/8" long

Tuning capacitors are air variable otherwise indicated.

2N4427

RF Low Power PA, LNA, and General Purpose Discrete Selector Guide

Packane	Device	Type	GPE Freq (MHz)	Pout (watts)	GPE (dB)	Efficiency (%)	GPE VCC	BVCEO	IC max (mA)
SO-8	MRF4427, R2	NPN	175	0.15	18	60	12	20	400
TO-39	2N4427	NPN	175	1	10	50	12	20	400
POWER MACRO	MRF553	NPN	175	1.5	11.5	60	12.5	16	500
POWER MACRO	MRF553T	NPN	175	1.5	11.5	50	12.5	16	500
TO-39	MRF607	NPN	175	1.75	11.5	50	12.5	16	330
TO-39	2N6255	NPN	175	3	7.8	50	12.5	18	1000
TO-72	2N5179	NPN	200		20	6	12	50	
MACRO X	MRF559	NPN	512	0.5	10	65	7.5	16	150
MACRO X	MRF559	NPN	512	0.5	13	60	12.5	16	150
TO-39	2N3866A	NPN	400	1	10	45	28	30	400
SO-8	MRF3866, R1, R2	NPN	400	1	10	45	28	30	400
POWER MACRO	MRF555	NPN	470	1.5	11	50	12.5	16	400
POWER MACRO	MRF555T	NPN	470	1.5	11	50	12.5	16	400
MACRO X	MRF559	NPN	870	0.5	6.5	70	7.5	16	150
MACRO X	MRF559	NPN	870	0.5	9.5	65	12.5	16	150
SO-8	MRF8372, R1, R2	NPN	870	0.75	8	55	12.5	16	200
POWER MACRO	MRF557	NPN	870	1.5	8	55	12.5	16	400
POWER MACRO	MRF557T	NPN	870	1.5	8	55	12.5	16	400

Packag	Device	Type	Freq (MHz)	NF	NF @ 100mA	NF VCE	GN (dB)	Gu Max (dB)	Ftau (MHz)	Ccb(pF)	BVCEO	IC max (mA)
TO-39	2N5109	NPN	200	3	10	15		12	1200	3.5	20	400
TO-39	MRF5943C	NPN	200	3.4	30	15		11.4	1000		30	400
SO-8	MRF5943, R1, R2	NPN	200	3.4	30	15		15	1300		30	400
TO-72	2N5179	NPN	200	4.5	1.5	6		17	900	1	12	50
TO-72	2N2857	NPN	300	5.5	50	6		13	1600	1	15	40
TO-39	MRF517	NPN	300	7.5	50	15		5.5	4600	3	25	150
TO-72	MRF904	NPN	450	1.5	5	6		11	4000	1	15	30
TO-72	2N6304	NPN	450	5	2	5		14	1400	1	15	50
MACRO T	BFR91	NPN	500	1.9	2	5	11	16.5	5000	1	12	35
MACRO T	BFR96	NPN	500	2	10	10		14.5	500	2.6	15	100
SO-8	MRF5812, R1, R2	NPN	500	2	50	10	15.5	17.8	5000		15	200
MACRO X	MRF581A	NPN	500	2	50	10	14	15	5000		15	200
Macro	BFR90	NPN	500	2.4	2	10	15	18	5000	1	15	30
TO-72	BFY90	NPN	500	2.5	2	5		20	1300		15	50
TO-72	MRF914	NPN	500	2.5	5	10		15	4500		12	40
MACRO X	MRF581	NPN	500	2.5	50	10	15	17.8	5000		16	200
TO-39	MRF586	NPN	500	3	90	15	11	14.5	4500	2.2	17	200
MACRO X	MRF951	NPN	1000	1.3	5	6	14	17	8000	0.45	10	100
MACRO X	MRF571	NPN	1000	1.5	10	6	10		8000	1	10	70
MACRO T	BFR91	NPN	1000	2.5	2	5	8	11	5000	1	12	35
MACRO T	BFR90	NPN	1000	3	2	10	10	12.5	5000	1	15	30
TO-39	MRF545	PNP						14	1400	2	70	400
TO-39	MRF544	NPN						13.5	1500		70	400

RF (Low Power PA / General Purpose) Selection Guide

RF (LNA / General Purpose) Selection Guide

Low Cost RF Plastic Package Options

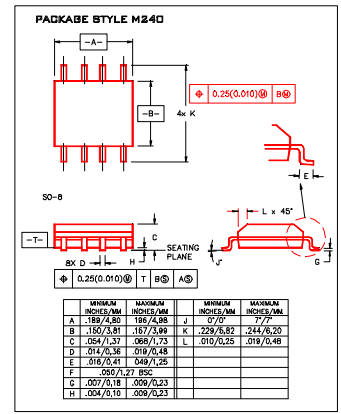
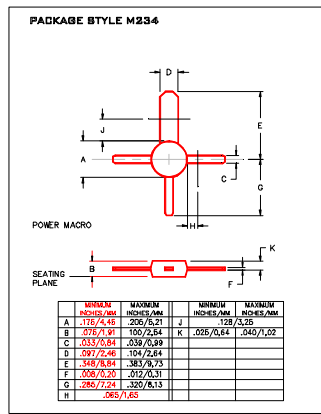
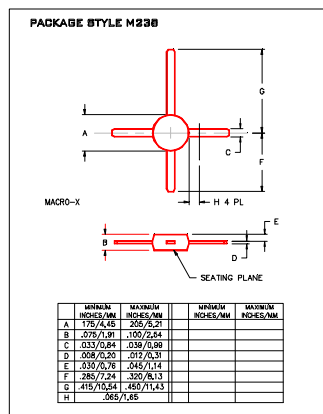
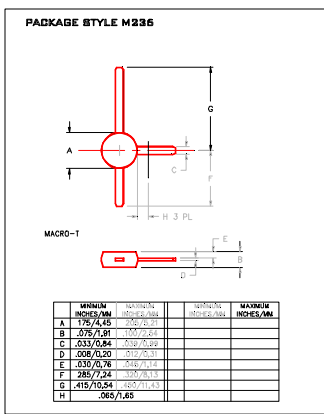

Macro T

Macro X

Power

SO-8

PACKAGE STYLE M246

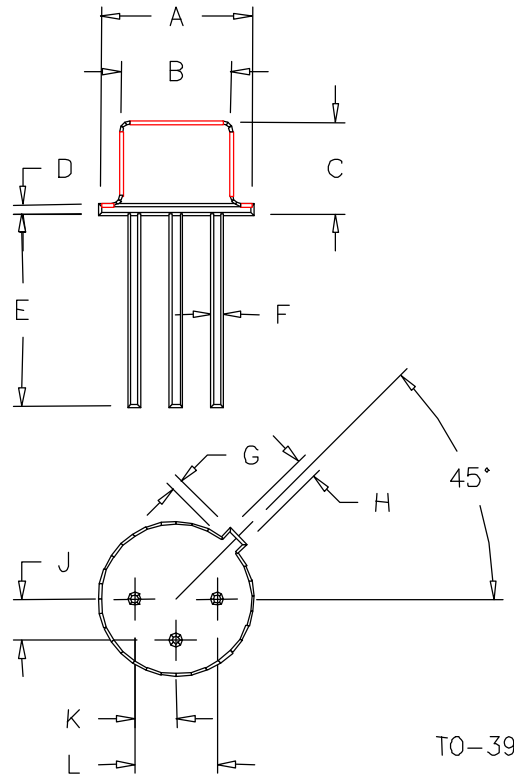

	MINIMUM INCHES/MM	MAXIMUM INCHES/MM		MINIMUM INCHES/MM	MAXIMUM INCHES/MM
A	.350/8,89	.370/9,40	J	.095/2,41	.105/2,67
B	.315/8,00	.335/8,51	K	.095/2,41	.105/2,67
C	.240/6,10	.260/6,60	L	.190/4,83	.210/5,33
D	.015/0,38	.045/1,14			
E	.500/12,70				
F	.016/0,41	.019/0,48			
G	.029/0,74	.040/1,02			
H	.028/0,71	.034/0,86			

Mouser Electronics

Authorized Distributor

Click to View Pricing, Inventory, Delivery & Lifecycle Information:

[Microchip:](#)

[2N4427](#)