

## Quad Operational Amplifier

### GENERAL DESCRIPTION

The XR-4136 is an array of four independent internally compensated operational amplifiers on a single silicon chip, each similar to the popular 741. Good thermal tracking and matched gain-bandwidth products make **these Quad Op-amps useful for active filter and signal conditioning applications.**

### FEATURES

Direct Pin-for-Pin Replacement for RC4136 and RM4136

#### Output Short-Circuit Protection

Internal Frequency Compensation

No Latch-Up

Wide Common-Mode and Differential Voltage Ranges

**Matched Gain-Bandwidth within a Package**

### APPLICATIONS

Buffer Amplifiers  
 Summing/Differencing Amplifiers  
 Instrumentation Amplifiers  
 Active Filters  
 Signal Processing  
 Sample and Differencing  
 I to V Converters  
 Integrators  
 Simulated Components  
**Analog Computers; Neural Networks**

### ABSOLUTE MAXIMUM RATINGS

Supply Voltage	
XR-4136M	± 22V
XR-4136C	± 18V
Common Mode	
Voltage Range	$V_{EE}$ to $V_{CC}$
Output Short-Circuit Duration	Indefinite
Differential Input Voltage	± 30V
Internal Power Dissipation	
Ceramic Package:	750 mW
Derate above $T_A = +25^\circ\text{C}$	6 mW/°C
Plastic Package:	625 mW
Derate above $T_A = +25^\circ\text{C}$	5 mW/°C
Storage Temperature Range:	-65°C to +150°C

### FUNCTIONAL BLOCK DIAGRAM

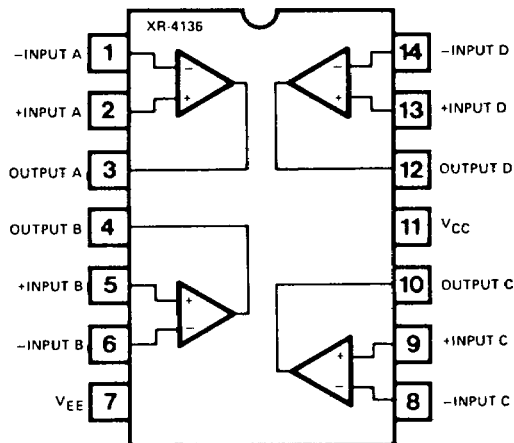

DataSheet4U.com

### ORDERING INFORMATION

Part Number	Package	Operating Temperature
XR-4136M	Ceramic	-55°C to +125°C
XR-4136CN	Ceramic	0°C to +70°C
XR-4136CP	Plastic	0°C to +70°C

### SYSTEM DESCRIPTION

The XR-4136 is a quad operational amplifier featuring similar characteristics to standard 741-type devices. As all four are monolithic, they have matched characteristics, including thermal tracking and gain bandwidth products.

**ELECTRICAL CHARACTERISTICS**

Test Conditions:  $T_A = +25^\circ\text{C}$ ,  $V_S = \pm 15\text{V}$ , unless otherwise specified.

SYMBOLS	PARAMETERS	XR4136M			XR4136C			UNITS	CONDITIONS
		MIN	TYP	MAX	MIN	TYP	MAX		
$ V_{io} $	Input Offset Voltage		.5	5.0		.5	6.0	mV	$R_S \leq 10\text{K}\Omega$
$ I_{io} $	Input Offset Current		5.0	200		5.0	200	nA	
$ I_b $	Input Bias Current		40	500		40	500	nA	
$R_{in}$	Input Resistance	0.3	5.0		0.3	5.0		M $\Omega$	
$A_{VOL}$	Large Signal Voltage Gain	50	300		20	300		V/mV	$R_L \geq 2\text{K}\Omega$ $V_{out} = \pm 10\text{V}$
$V_{out}$	Output Voltage Swing	$\pm 12$	$\pm 14$		$\pm 12$	$\pm 14$		V	$R_L \geq 10\text{K}\Omega$
$V_{out}$		$\pm 10$	$\pm 13$		$\pm 10$	$\pm 13$		V	$R_L \geq 2\text{K}\Omega$
$V_{ICM}$	Input Voltage range	$\pm 12$	$\pm 14.0$		$\pm 12$	$\pm 14.0$		V	
CMRR	Common Mode Rejection Ratio	70	105		70	105		dB	$R_S \leq 10\text{K}\Omega$
PSRR	Supply Voltage Rejection Ratio		10	150		10	150	$\mu\text{V/V}$	$R_S \leq 10\text{K}\Omega$
$P_I$	Power Consumption		210	340		210	340	mW	
$t_r$ $t_o$	Transient Response (unity gain) Risetime Overshoot		.13 5.0			.13 5.0		$\mu\text{s}$ %	$V_{in} = 20\text{mV}$ $R_L = 2\text{K}\Omega$ $C_L \leq 100\text{pF}$
BW	Unity Gain Bandwidth	2.0	3.0			3.0		MHz	
$dV_{out}/dt$	Slew Rate (unity gain)		1.5			1		V/ $\mu\text{s}$	$R_L \geq 2\text{K}\Omega$
	Channel Separation (open loop)		105			105		dB	$f = 10\text{KHz}$ $R_S = 1\text{K}\Omega$
	(Gain of 100)		105			105		dB	$f = 10\text{KHz}$ $R_S = 1\text{K}\Omega$
The following specifications apply for $-55^\circ\text{C} \leq T_A \leq +125^\circ\text{C}$ for XR-4136M: $0^\circ\text{C} \leq T_A \leq +70^\circ\text{C}$ for XR-4136C									
$ V_{io} $	Input Offset Voltage			6.0			7.5	mV	$R_S \leq 10\text{K}\Omega$
$ I_{io} $	Input Offset Current			500			300	nA	
$I_b$	Input Bias Current			1500			800	nA	
$A_{VOL}$	Large-Signal Voltage Gain	25			15			V/mV	$R_L \geq 2\text{K}\Omega$ $V_{out} = \pm 10\text{V}$
$V_{out}$	Output Voltage Swing	$\pm 10$			$\pm 10$			V	$R_L \geq 2\text{K}\Omega$
$P_I$ $P_i$	Power Consumption		180 240	300 400		100 240	300 400	mW mW	$V_S = \pm 15\text{V}$ $T_A = \text{High}$ $T_A = \text{Low}$
$I_{SC}$	Output Short-Circuit Current		45			45		mA	

**TYPICAL PARAMETER MATCHING:**

Test Conditions:  $T_A = +25^\circ\text{C}$ ,  $V_S = \pm 15\text{V}$  unless otherwise noted

SYMBOLS	PARAMETERS	XR4136M TYP	XR4136C TYP	UNITS	CONDITIONS
$ V_{io} $	Input Offset Voltage	$\pm 1.0$	$\pm 2.0$	mV	$R_S \geq 10\text{K}\Omega$
$ I_{io} $	Input Offset Current	$\pm 7.5$	$\pm 7.5$	nA	
$I_b$	Input Bias Current	$\pm 15$	$\pm 15$	nA	
$A_{VOL}$	Voltage Gain	$\pm 0.5$	$\pm 1.0$	dB	$R_S \geq 2\text{K}\Omega$

# XR-4136

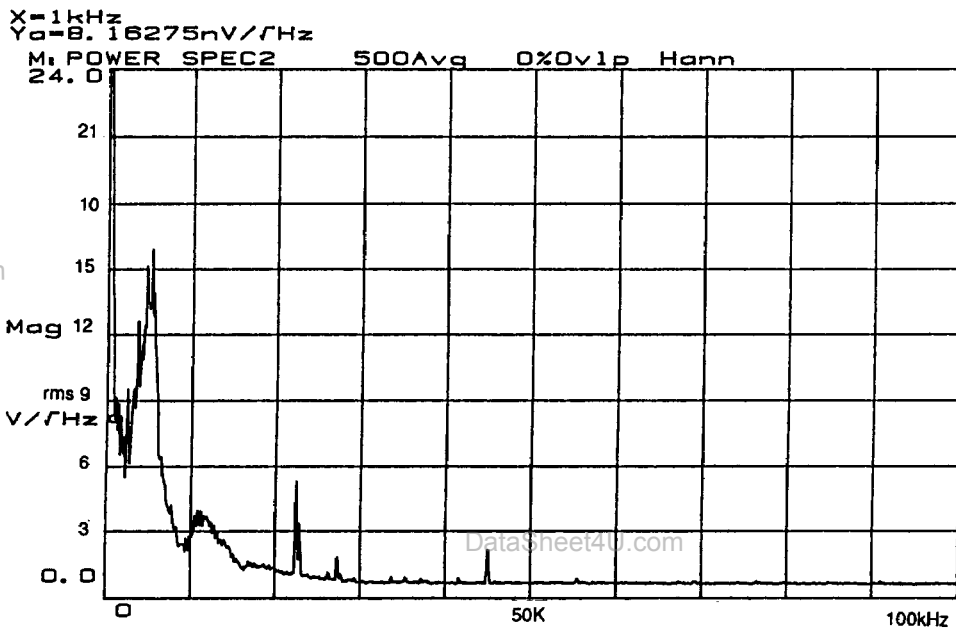

et4U.com

DataShee

3422618 EXAR CORP

**EXAR**

91D 04225

D7-75-45-05

**XR-1488/1489A**

## Quad Line Driver/Receiver

### GENERAL DESCRIPTION

The XR-1488 is a monolithic quad line driver designed to interface data terminal equipment with data communications equipment in conformance with the specifications of EIA Standard No. RS232C. This extremely versatile integrated circuit can be used to perform a wide range of applications. Features such as output current limiting, independent positive and negative power supply driving elements, and compatibility with all DTL and TTL logic families greatly enhance the versatility of the circuit.

The XR-1489A is a monolithic quad line receiver designed to interface data terminal equipment with data communications equipment. The XR-1489A quad receiver along with its companion circuit, the XR-1488 quad driver, provide a complete interface system between DTL or TTL logic levels and the RS232C defined voltage and impedance levels.

### FUNCTIONAL BLOCK DIAGRAMS

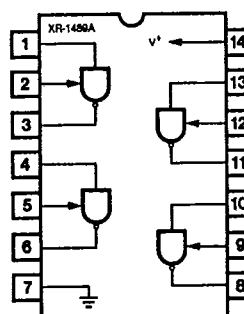
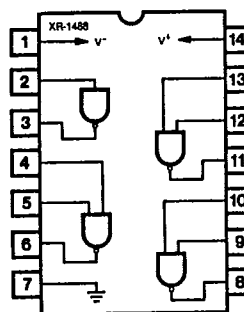

### ABSOLUTE MAXIMUM RATINGS

Power Supply	
XR-1488	$\pm 15$ Vdc
XR-1489A	+ 10 Vdc
Power Dissipation	
Ceramic Package	1000 mW
Derate above +25°C	6.7 mW/°C
Plastic Package	650 mW/°C
Derate above +25°C	5 mW/°C

DataSheet4U.com

### ORDERING INFORMATION

Part Number	Package	Operating Temperature
XR-1488N	Ceramic	0°C to +70°C
XR-1488P	Plastic	0°C to +70°C
XR-1489AN	Ceramic	0°C to +70°C
XR-1489AP	Plastic	0°C to +70°C

### SYSTEM DESCRIPTION

The XR-1488 and XR-1489A are a matched set of quad line drivers and line receivers designed for interfacing between TTL/DTL and RS232C data communication lines.

The XR-1488 contains four independent split supply line drivers, each with a  $\pm 10$  mA current limited output. For RS232C applications, the slew rate can be reduced to the 30 V/ $\mu$ S limit by shunting the output to ground with a 410 pF capacitor. The XR-1489A contains four independent line receivers, designed for interfacing RS232C to TTL/DTL. Each receiver features independently programmable switching thresholds with hysteresis, and input protection to  $\pm 30$  V. The output can typically source 3 mA and sink 20 mA.