

***THIS DOCUMENT IS FOR MAINTENANCE
PURPOSES ONLY AND IS NOT
RECOMMENDED FOR NEW DESIGNS***

SL490B

REMOTE CONTROL TRANSMITTER

(Supersedes version in April 1994 Consumer IC Handbook, HB3120 - 2.0)

GPS has developed and produced a range of monolithic integrated circuits which give a wide variety of remote control facilities. As well as ultrasonic or infra-red transmission, cable, radio or telephone links may also be used. Pulse Position Modulation (PPM) is used with or without carrier and automatic error detection is incorporated. Initially designed with TV remote control in mind, the device is also suitable for use in radios, tuners, tape and record decks, lamps and lighting, toys and models, industrial control and monitoring.

The SL490B is an easily extendable, 32-command PPM transmitter drawing negligible standby current.

FEATURES

- Ultrasonic or Infra-Red Transmission
- Direct Drive or Ultrasonic Transducer
- Direct Drive of Visible LED when using Infra-Red
- Very Low Power Requirements
- Pulse Position Modulation gives Excellent Immunity from Noise and Multipath Reflections
- Single Pole Key Matrix
- Switch Resistance up to 1kΩ Tolerated
- Low External Component Count
- On-Chip Anti-Bounce Circuitry

ABSOLUTE MAXIMUM RATINGS

Supply voltage, V_{CC}	+9-5V
Total power dissipation	600mW
Operating temperature range	-10°C to +60°C
Storage temperature range	-55°C to +150°C

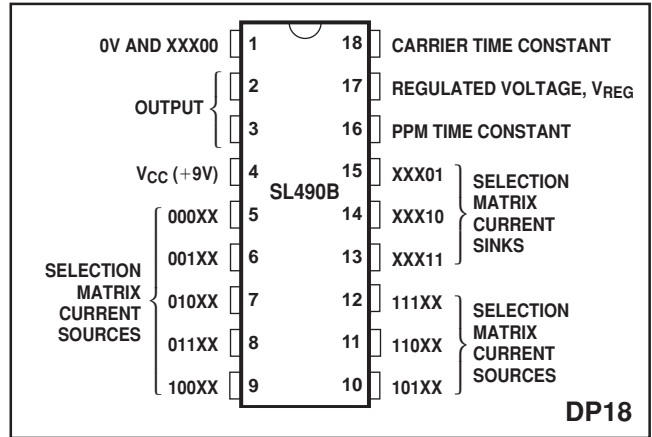

Fig. 1 Pin connections - top view

QUICK REFERENCE DATA

- Power Supply: 9V Standby 6μA, Operating 8mA
- Modulation: Pulse Position with or without Carrier
- Coding: 5-Bit Word giving a Primary Command Set of 32 Commands
- Key Entry: 8 × 4 Single Pole Key Matrix
- Data Rate: Selectable 1Bit/Sec to 10kBit/Sec.
- Carrier Frequency: Selectable 0Hz (No Carrier) to 200kHz

ORDERING INFORMATION

SL490B NA DP

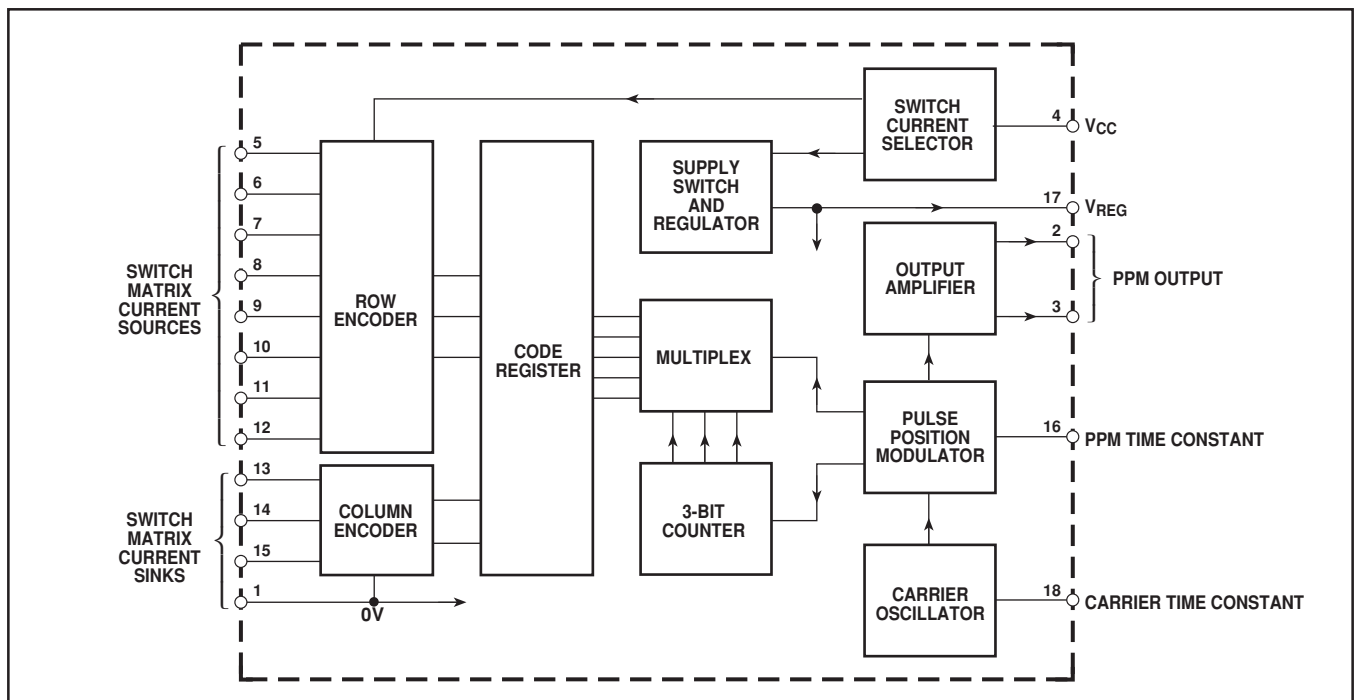

Fig. 2 SL490B block diagram

ELECTRICAL CHARACTERISTICS

These characteristics are guaranteed over the following conditions (unless otherwise stated):

$T_{AMB} = +25^{\circ}\text{C}$, $V_{CC} = +7\text{V}$ to $+10.5\text{V}$. Test circuit: Fig. 4. Timings are defined in Fig. 3.

Characteristic	Pin	Value			Units	Conditions
		Min.	Typ.	Max.		
Operating supply current	4		9.5	16	mA	$V_{CC} = 9.5\text{V}$
Standby supply current	4			10	μA	
Regulated voltage, V_{REG}	17	4.1		4.9	V	
Regulator output current, I_{REG}	17			1	mA	
Output voltage swing	2,3	$V_{CC} - 1$			V	Unloaded
Output voltage	2			1	V	} peak value <1ms $I_2 = 10\text{mA}$ $I_3 = 5\text{mA}$
Output voltage	3			1	V	
Keypad switch resistance	5-15			5	k Ω	
Carrier time constant resistor, R2	18	20	40	80	k Ω	$C2 = 680\text{pF}$, $f_c \approx 50\text{kHz}$; see Fig. 4
PPM time constant resistor, R1	16	15	30	60	k Ω	
t_1 deviation from calculated value, using fixed timing components	2,3			± 10	%	} $t_1 = 0.95C1R1$, see Fig. 4 $R1 = 60\text{k}\Omega$
Variation of t_1 and t_0 with V_{CC}				± 10	%	
Δt_1	2,3			± 4	%	} $\Delta V_{CC} = 3.5\text{V}$ (7V to 10.5V)
Δt_0	2,3			± 4	%	
Ratio t_0/t_1	2,3	1.4		1.6		
Pulse width, t_p	2,3	$0.11t_1$		$0.22t_1$		
Interword gap, t_g	2,3		$3t_1$			Derived by counting

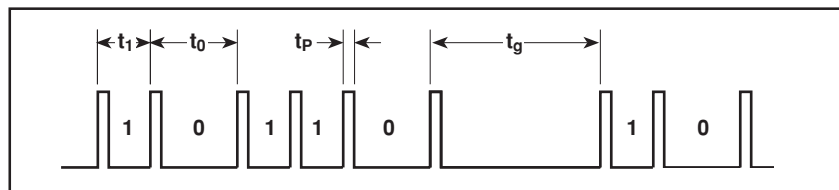

Fig. 3 PPM word notation and timing definitions

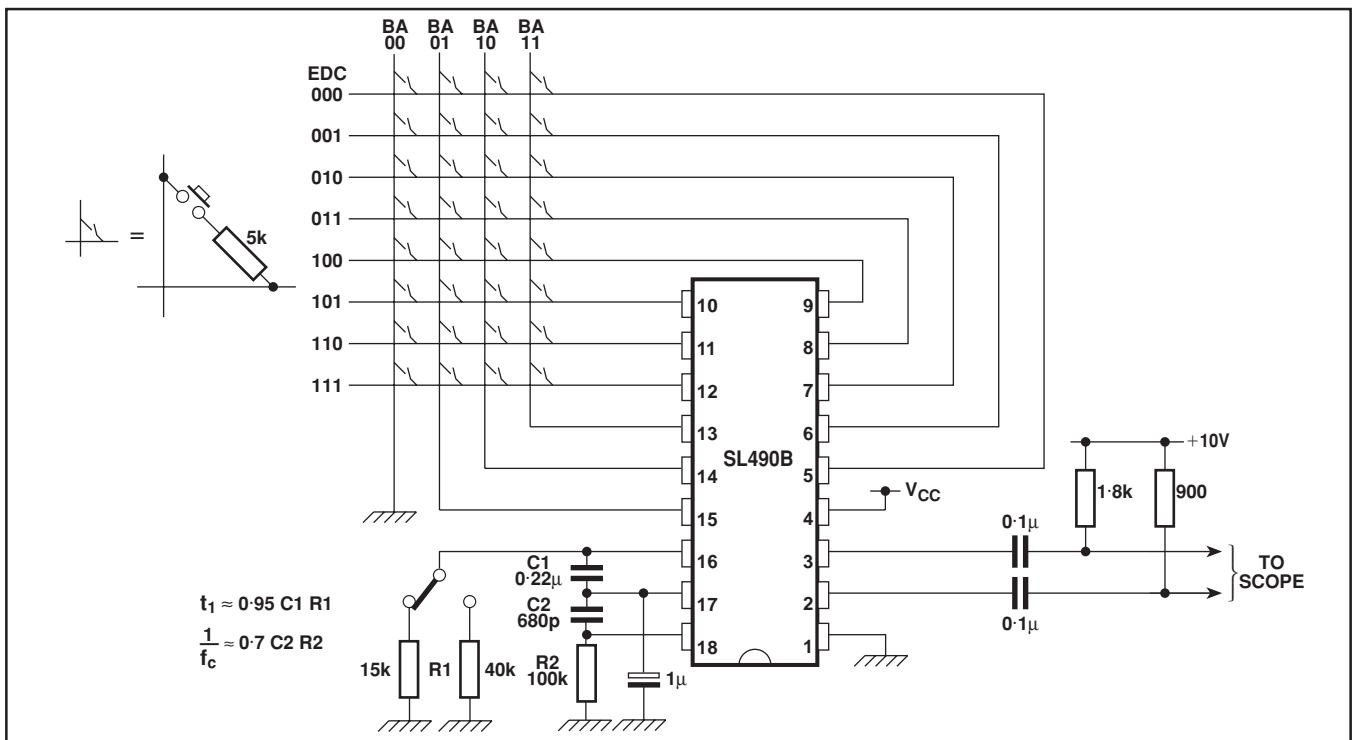

Fig. 4 Test circuit

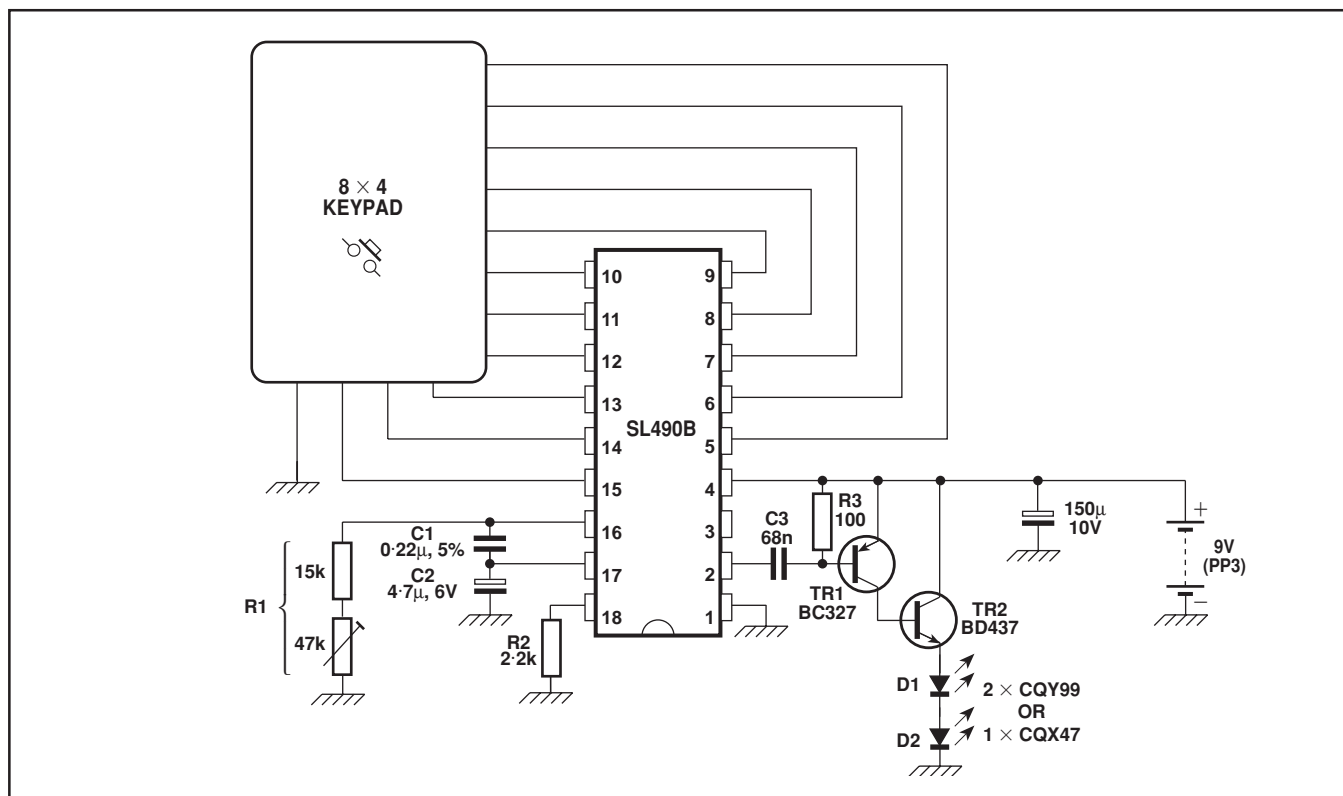

Fig. 5 Infra-red application circuit

OPERATING NOTES

Fig. 5 shows the circuit for a simple infra-red transmitter where the PPM output pulses from pin 2 of the SL490B are differentiated by C3 and R3 and amplified by TR1 to produce current pulses about 15µs wide. These pulses are further amplified by TR2 and applied to the infra-red diodes D1 and D2.

The current in the diodes and the infra-red output is controlled by the quantity, type, and connection method of the diodes and also by the gain, at high currents, of the transistors.

The most common solution where cost is important is to use two single-chip diodes, such as the CQY99 connected in series.

Improved output can be obtained by using four CQY99 diodes in a series/parallel arrangement, but it is usually simpler to use two multi-chip diodes such as the CQX47 connected in parallel or a single CQX19, which gives similar results.

A significant increase in range can be obtained by using diodes such as the CQY99 in conjunction with a plated plastic parabolic reflector.

When building the transmitter, care should be taken with the choice of the capacitor C4 and with the circuit layout, particularly when multi-chip diodes are being used, as the current pulses can be as high as 6 to 8A.

Transistor choice is also important and any substitutes should have high current gain characteristics and switching speeds compatible with the application.

An increase in output can be obtained by connecting TR2 in common emitter configuration, but care should be taken not to exceed the rating of the diodes.

Choice of PPM Frequency

When the transmitter is being used with an infra-red link, with high current pulses fed to the diodes as in Fig. 5, power consumption will increase with frequency. It is thus advisable that, with a battery power supply, the slowest PPM rate consistent with adequate response time should be chosen.

PACKAGE DETAILS

Dimensions are shown thus: mm (in)

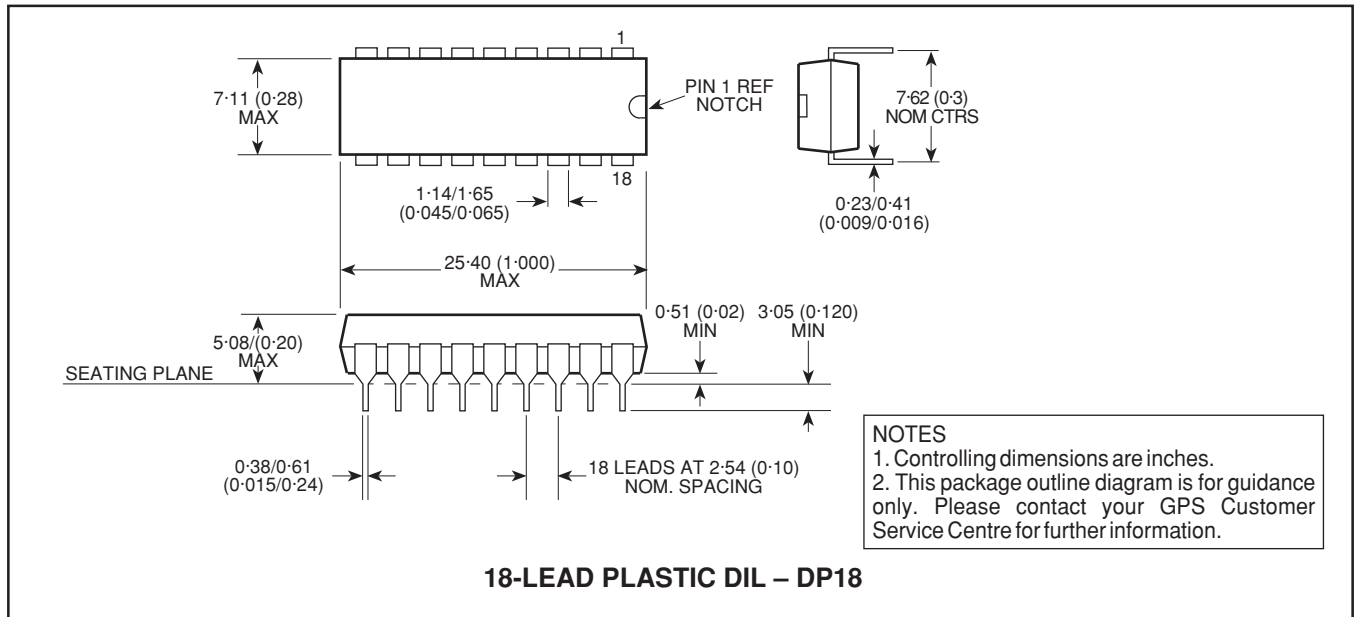

HEADQUARTERS OPERATIONS
GEC PLESSEY SEMICONDUCTORS
 Cheney Manor, Swindon,
 Wiltshire SN2 2QW, United Kingdom.
 Tel: (0793) 518000
 Fax: (0793) 518411

GEC PLESSEY SEMICONDUCTORS
 P.O. Box 660017
 1500 Green Hills Road,
 Scotts Valley, CA95067-0017
 United States of America.
 Tel (408) 438 2900
 Fax: (408) 438 5576

CUSTOMER SERVICE CENTRES

- **FRANCE & BENELUX** Les Ulis Cedex Tel: (1) 64 46 23 45 Fax : (1) 64 46 06 07
- **GERMANY** Munich Tel: (089) 3609 06-0 Fax : (089) 3609 06-55
- **ITALY** Milan Tel: (02) 66040867 Fax: (02) 66040993
- **JAPAN** Tokyo Tel: (3) 5276-5501 Fax: (3) 5276-5510
- **NORTH AMERICA** Scotts Valley, USA Tel: (408) 438 2900 Fax: (408) 438 7023.
- **SOUTH EAST ASIA** Singapore Tel: (65) 3827708 Fax: (65) 3828872
- **SWEDEN** Stockholm Tel: 46 8 702 97 70 Fax: 46 8 640 47 36
- **UK, EIRE, DENMARK, FINLAND & NORWAY**
 Swindon Tel: (0793) 518510 Fax : (0793) 518582

These are supported by Agents and Distributors in major countries world-wide.

© GEC Plessey Semiconductors 1994 Publication No. DS3056 Issue No. 1.3 April 1995

This publication is issued to provide information only which (unless agreed by the Company in writing) may not be used, applied or reproduced for any purpose nor form part of any order or contract nor to be regarded as a representation relating to the products or services concerned. No warranty or guarantee express or implied is made regarding the capability, performance or suitability of any product or service. The Company reserves the right to alter without prior knowledge the specification, design or price of any product or service. Information concerning possible methods of use is provided as a guide only and does not constitute any guarantee that such methods of use will be satisfactory in a specific piece of equipment. It is the user's responsibility to fully determine the performance and suitability of any equipment using such information and to ensure that any publication or data used is up to date and has not been superseded. These products are not suitable for use in any medical products whose failure to perform may result in significant injury or death to the user. All products and materials are sold and services provided subject to the Company's conditions of sale, which are available on request.