

MM54C915/MM74C915 7-Segment-to-BCD Converter

General Description

The MM54C915/MM74C915 is a monolithic complementary MOS (CMOS) integrated circuit, constructed with N- and P-channel enhancement-mode transistors. This circuit accepts 7-segment information and converts it into BCD information. The true state of the Segment inputs can be selected by use of the Invert/Non-Invert control pin. A logical "0" on the Invert/Non-Invert control pin selects active high true decoding at the Segment inputs. A logical "1" on the Invert/Non-Invert control pin selects active low true decoding at the Segment inputs. In addition to 4 TTL compatible BCD outputs, an Error output and Minus output are available. The Error output goes to an active "1" whenever a non-standard 7-segment code appears at the Segment input. The BCD outputs are forced into a TRI-STATE® condition when an error is detected. This allows the user to program his own error code by tying the BCD outputs to V_{CC} or Ground via high value resistors (~500k). The BCD outputs may also be forced into TRI-STATE by a logical "1" on output enable (OE).

The Minus output goes to a logical "1" whenever a minus code is detected and is useful as a microprocessor interrupt. The BCD outputs are in a flow-through condition when Latch Enable (LE) is at a logical "0" and latched when LE is at a logical "1". The inputs will not clamp signals to the positive supply, allowing simple level translation from MOS to TTL.

Features

- Wide supply range 3V-15V
- High noise immunity 0.45 V_{CC} (typ.)
- TTL compatible fan out 1 TTL load
- Selectable active true inputs
- TRI-STATE outputs
- On-chip latch
- Error output
- Minus output

Logic Diagram

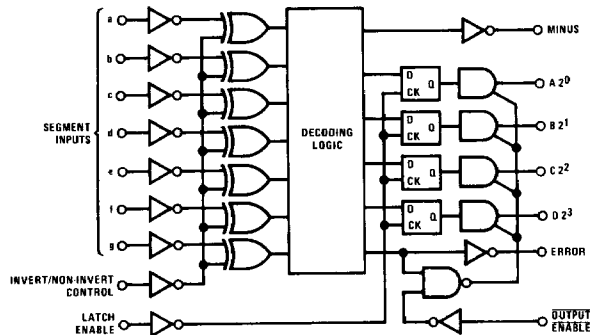

TL/F/5918-1

Connection Diagram

Dual-In-Line Package

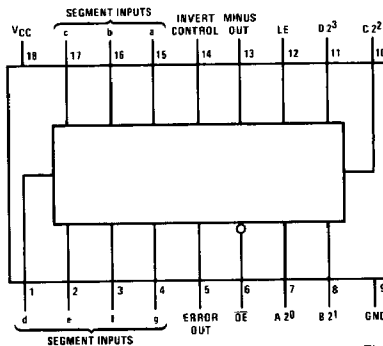

TL/F/5918-2

Top View

Order Number MM54C915* or MM74C915*

*Please look into Section 8, Appendix D for availability of various package types.

Absolute Maximum Ratings (Note 1)

If Military/Aerospace specified devices are required, contact the National Semiconductor Sales Office/Distributors for availability and specifications.

Voltage at Any Output	-0.3V to $V_{CC} + 0.3V$
Voltage at Any Input	-0.3V to 18V
Operating Temperature Range	
MM54C915	-55°C to +125°C
MM74C915	-40°C to +85°C

Storage Temperature Range	-65°C to +150°C
Power Dissipation	
Dual-In-Line	700 mW
Small Outline	500 mW
Operating V_{CC} Range	4.0V to 15V
Maximum V_{CC}	18V
Lead Temperature (Soldering, 10 seconds)	260°C

DC Electrical Characteristics Min/Max limits apply across temperature range, unless otherwise noted

Symbol	Parameter	Conditions	Min	Typ	Max	Units
CMOS TO CMOS						
$V_{IN(1)}$	Logical "1" Input Voltage	$V_{CC} = 5V$	3.5			V
		$V_{CC} = 10V$	8.0			V
		$V_{CC} = 15V$	12.5			V
$V_{IN(0)}$	Logical "0" Input Voltage	$V_{CC} = 5V$			1.5	V
		$V_{CC} = 10V$			2.0	V
		$V_{CC} = 15V$			2.5	V
$I_{IN(1)}$	Logical "1" Input Current	$V_{IN} = 15V$		0.005	1.0	μA
$I_{IN(0)}$	Logical "0" Input Current	$V_{IN} = 0V$	-1.0	-0.005		μA
$V_{OUT(1)}$	Logical "1" Output Voltage	$I_O = 10 \mu A$				
		$V_{CC} = 5V$	4.5			V
		$V_{CC} = 10V$	9.0			V
		$V_{CC} = 15V$	13.5			V
$V_{OUT(0)}$	Logical "0" Output Voltage	$I_O = 10 \mu A$				
		$V_{CC} = 5V$			0.5	V
		$V_{CC} = 10V$			1.0	V
		$V_{CC} = 15V$			1.5	V
I_{CC}	Supply Current	$V_{CC} = 5V$		0.25	1	mA
		$V_{CC} = 10V$		0.75	2.5	mA
		$V_{CC} = 15V$		1.00	3.0	mA
CMOS/TTL INTERFACE						
$V_{IN(1)}$	Logical "1" Input Voltage MM54C915 MM74C915	$V_{CC} = 4.5V$	$V_{CC} - 1.7$			V
		$V_{CC} = 4.75V$	$V_{CC} - 1.7$			V
$V_{IN(0)}$	Logical "0" Input Voltage MM54C915 MM74C915	$V_{CC} = 4.5V$			0.8	V
		$V_{CC} = 4.75V$			0.8	V
$V_{OUT(1)}$	Logical "1" Output Voltage MM54C915 MM74C915	$I_O = -360 \mu A$				
		$V_{CC} = 4.5V$	2.4			V
		$V_{CC} = 4.75V$	2.4			V
$V_{OUT(0)}$	Logical "0" Output Voltage MM54C915 MM74C915	$I_O = 1.6 mA$				
		$V_{CC} = 4.5V$			0.4	V
		$V_{CC} = 4.75V$			0.4	V
OUTPUT DRIVE (Short Circuit Current)						
I_{SOURCE}	Output Source Current P-Channel	$T_A = 25^\circ C, V_O = 0V$ (Note 2)				
		$V_{CC} = 5V$	-1.75	-3.3		mA
		$V_{CC} = 10V$	-8	-15		mA
		$V_{CC} = 15V$	-15	-25		mA
I_{SINK}	Output Sink Current N-Channel	$T_A = 25^\circ C, V_O = V_{CC}$ (Note 2)				
		$V_{CC} = 5V$	5	8		mA
		$V_{CC} = 10V$	20	30		mA
		$V_{CC} = 15V$	30	50		mA

AC Electrical Characteristics* $T_A = 25^\circ\text{C}$

Symbol	Parameter	Conditions	Min	Typ	Max	Units
t_{pd0}, t_{pd1}	Propagation Delay Time to Logical "0" or Logical "1"	$C_L = 50\text{ pF}$ $V_{CC} = 5\text{V}$ $V_{CC} = 10\text{V}$ $V_{CC} = 15\text{V}$		500 300 300	1000 600 600	ns ns ns
t_{0H}, t_{1H}	Propagation Delay Time from Logical "0" or Logical "1" into High Impedance State	$R_L = 10\text{ k}\Omega, C_L = 10\text{ pF}$ $V_{CC} = 5\text{V}$ $V_{CC} = 10\text{V}$ $V_{CC} = 15\text{V}$		110 75 60	200 130 110	ns ns ns
t_{H0}, t_{H1}	Propagation Delay Time from High Impedance State to a Logical "0" or Logical "1"	$R_L = 10\text{ k}\Omega, C_L = 50\text{ pF}$ $V_{CC} = 5\text{V}$ $V_{CC} = 10\text{V}$ $V_{CC} = 15\text{V}$		150 80 70	250 140 125	ns ns ns
t_s	Input Data Set-Up Time	$C_L = 50\text{ pF}$ $V_{CC} = 5\text{V}$ $V_{CC} = 10\text{V}$ $V_{CC} = 15\text{V}$		500 300 300	1000 600 600	ns ns ns
t_H	Input Data Hold Time	$C_L = 50\text{ pF}$ $V_{CC} = 5\text{V}$ $V_{CC} = 10\text{V}$ $V_{CC} = 15\text{V}$		-150 -100 -100	0 0 0	ns ns ns
C_{IN}	Input Capacitance	Any Input (Note 3)		5	7.5	pF
C_{OUT}	TRI-STATE Output Capacitance	Any Output (Note 3)		10		pF

*AC Parameters are guaranteed by DC correlated testing.

Note 1: "Absolute Maximum Ratings" are those values beyond which the safety of the device cannot be guaranteed. Except for "Operating Temperature Range" they are not meant to imply that the devices should be operated at these limits. The table of "Electrical Characteristics" provides conditions for actual device operation.

Note 2: These specifications apply to transient operation. It is not meant to imply that the device should be operated at these limits in sustained operation.

Note 3: Capacitance is guaranteed by periodic testing.

Truth Table

CHARACTER AT SEGMENT INPUTS	BCD OUTPUTS				NON-BCD OUTPUTS	
	D 2^3	C 2^2	B 2^1	A 2^0	ERROR	MINUS
	0	0	0	0	0	0
1	0	0	0	1	0	0
2	0	0	0	1	0	0
3	0	0	1	0	0	0
4	0	0	1	1	0	0
5	0	1	0	0	0	0
6	0	1	0	1	0	0
7	0	1	1	0	0	0
8	0	1	1	1	0	0
9	0	1	1	1	0	0
10	1	0	0	0	0	0
11	1	0	0	1	0	0
12	1	0	0	1	0	0
13	1	1	1	1	0	0
14	X	X	X	X	1	1
15	X	X	X	X	1	0
All other input combinations	X	X	X	X	1	0

X = represents TRI-STATE condition

Segment Identification

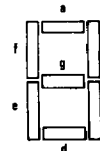

TL/F/5918-4

TL/F/5918-3

Typical Applications

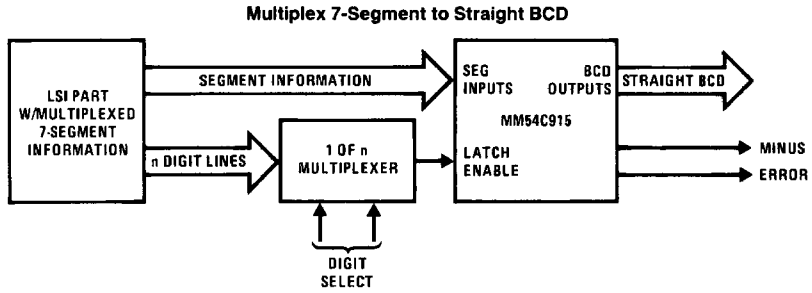

TL/F/5918-5

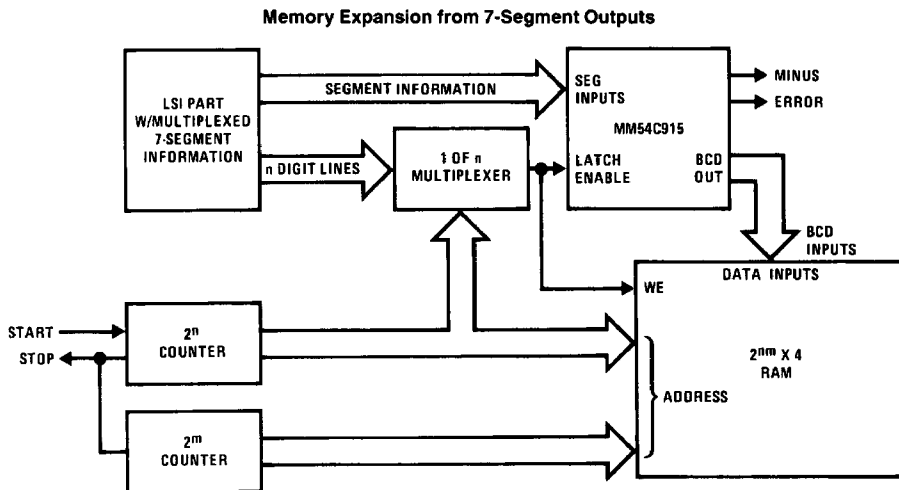

TL/F/5918-6